

Macmillan McGraw-Hill

California
Mathematics

5

**Homework Practice
and Problem-Solving
Practice Workbook**



Macmillan/McGraw-Hill

TO THE TEACHER These worksheets are the same ones found in the Chapter Resource Masters for *California Mathematics, Grade 5*. The answers to these worksheets are available at the end of each Chapter Resource Masters booklet.



The McGraw-Hill Companies

Copyright © by the McGraw-Hill Companies, Inc. All rights reserved.
Except as permitted under the United States Copyright Act, no part of this publication may be reproduced or distributed in any form or by any means, or stored in a database or retrieval system, without prior written permission of the publisher.

Send all inquiries to:
Macmillan/McGraw-Hill
8787 Orion Place
Columbus, OH 43240

ISBN: 978-0-02-111969-1
MHID: 0-02-111969-4

Homework Practice/Problem Solving Practice Workbook, Grade 5

Printed in the United States of America.

4 5 6 7 8 9 10 11 12 13 045 17 16 15 14 13 12 11 10 09

Contents

Chapter 1 Number Sense, Algebra, and Functions

| | |
|---|----|
| 1-1 Prime Factors | 1 |
| 1-2 Powers and Exponents | 3 |
| 1-3 Order of Operations..... | 5 |
| 1-4 Problem-Solving Investigation: Use the Four-Step Plan..... | 7 |
| 1-5 Algebra: Variables and Expressions..... | 9 |
| 1-6 Algebra: Functions..... | 11 |
| 1-7 Problem-Solving Strategy: Guess and Check..... | 13 |
| 1-8 Algebra: Equations | 15 |
| 1-9 Algebra: Area Formulas | 17 |
| 1-10 Algebra: The Distributive Property..... | 19 |

Chapter 2 Statistics and Data Analysis

| | |
|---|----|
| 2-1 Bar Graphs and Line Graphs..... | 21 |
| 2-2 Interpret Line Graphs | 23 |
| 2-3 Histograms..... | 25 |
| 2-4 Line Plots..... | 27 |
| 2-5 Problem-Solving Strategy: Make a Table..... | 29 |
| 2-6 Mean..... | 31 |
| 2-7 Median, Mode, and Range | 33 |
| 2-8 Problem-Solving Investigation: Extra or Missing Information..... | 35 |
| 2-9 Selecting an Appropriate Display | 37 |
| 2-10 Integers and Graphing..... | 39 |

Chapter 3 Adding and Subtracting Decimals

| | |
|---|----|
| 3-1 Representing Decimals..... | 41 |
| 3-2 Comparing and Ordering Whole Numbers and Decimals..... | 43 |
| 3-3 Rounding Whole Numbers and Decimals..... | 45 |
| 3-4 Problem-Solving Strategy: Use Logical Reasoning..... | 47 |
| 3-5 Estimating Sums and Differences | 49 |
| 3-6 Problem-Solving Investigation: Use Estimation..... | 51 |
| 3-7 Adding and Subtracting Decimals..... | 53 |

Chapter 4 Fractions and Decimals

| | |
|--|----|
| 4-1 Greatest Common Factor..... | 55 |
| 4-2 Problem-Solving Strategy: Make an Organized List..... | 57 |
| 4-3 Simplifying Fractions..... | 59 |
| 4-4 Mixed Numbers and Improper Fractions... | 61 |

| | |
|---|----|
| 4-5 Least Common Multiple..... | 63 |
| 4-6 Problem-Solving Investigation: Choose the Best Strategy..... | 65 |
| 4-7 Comparing Fractions..... | 67 |
| 4-8 Writing Decimals as Fractions..... | 69 |
| 4-9 Writing Fractions as Decimals..... | 71 |
| 4-10 Algebra: Ordered Pairs and Functions | 73 |

Chapter 5 Adding and Subtracting Fractions

| | |
|--|----|
| 5-1 Rounding Fractions and Mixed Numbers..... | 75 |
| 5-2 Estimating Sums and Differences..... | 77 |
| 5-3 Adding and Subtracting Fractions with Like Denominators | 79 |
| 5-4 Problem-Solving Strategy: Act It Out..... | 81 |
| 5-5 Adding and Subtracting Fractions with Unlike Denominators | 83 |
| 5-6 Problem-Solving Investigation: Choose the Best Strategy..... | 85 |
| 5-7 Adding and Subtracting Mixed Numbers..... | 87 |
| 5-8 Subtracting Mixed Numbers with Renaming | 89 |

Chapter 6 Multiplying and Dividing Decimals and Fractions

| | |
|---|-----|
| 6-1 Multiplying Decimals by Whole Numbers..... | 91 |
| 6-2 Multiplying Decimals..... | 93 |
| 6-3 Problem-Solving Strategy: Reasonable Answers | 95 |
| 6-4 Dividing Decimals by Whole Numbers..... | 97 |
| 6-5 Dividing by Decimals..... | 99 |
| 6-6 Problem-Solving Investigation: Choose the Best Strategy..... | 101 |
| 6-7 Estimating Products of Fractions | 103 |
| 6-8 Multiplying Fractions..... | 105 |
| 6-9 Multiplying Mixed Numbers..... | 107 |
| 6-10 Dividing Fractions..... | 109 |
| 6-11 Dividing Mixed Numbers..... | 111 |

Chapter 7 Algebra: Integers and Equations

| | |
|--|-----|
| 7-1 Ordering Integers..... | 113 |
| 7-2 Adding Integers | 115 |
| 7-3 Subtracting Integers..... | 117 |
| 7-4 Multiplying Integers | 119 |
| 7-5 Problem-Solving Strategy: Work Backward | 121 |

| | |
|---|-----|
| 7-6 Dividing Integers..... | 123 |
| 7-7 Problem-Solving Investigation: Choose the Best Strategy..... | 125 |
| 7-8 The Coordinate Plane | 127 |
| 7-9 Solving Addition Equations | 129 |
| 7-10 Solving Subtraction Equations..... | 131 |
| 7-11 Solving Multiplication Equations..... | 133 |

Chapter 8 Algebra: Ratios and Functions

| | |
|---|-----|
| 8-1 Ratios and Rates | 135 |
| 8-2 Problem-Solving Strategy: Look for a Pattern..... | 137 |
| 8-3 Ratio Tables..... | 139 |
| 8-4 Equivalent Ratios | 141 |
| 8-5 Problem-Solving Investigation: Choose the Best Strategy..... | 143 |
| 8-6 Algebra: Ratios and Equations | 145 |
| 8-7 Algebra: Sequences and Expressions..... | 147 |
| 8-8 Algebra: Equations and Graphs | 149 |

Chapter 9 Percent

| | |
|---|-----|
| 9-1 Percents and Fractions..... | 151 |
| 9-2 Circle Graphs..... | 153 |
| 9-3 Percents and Decimals | 155 |
| 9-4 Problem-Solving Strategy: Solve a Simpler Problem..... | 157 |
| 9-5 Estimating with Percents..... | 159 |
| 9-6 Percent of a Number..... | 161 |
| 9-7 Problem-Solving Investigation: Choose the Best Strategy..... | 163 |

| | |
|------------------------------|-----|
| 9-8 Probability | 165 |
| 9-9 Sample Spaces | 167 |
| 9-10 Making Predictions..... | 169 |

Chapter 10 Geometry: Angles and Polygons

| | |
|--|-----|
| 10-1 Measuring Angles..... | 171 |
| 10-2 Problem-Solving Strategy: Draw a Diagram..... | 173 |
| 10-3 Estimating and Drawing Angles..... | 175 |
| 10-4 Parallel and Perpendicular Lines | 177 |
| 10-5 Problem-Solving Investigation: Choose the Best Strategy..... | 179 |
| 10-6 Triangles..... | 181 |
| 10-7 Quadrilaterals..... | 183 |
| 10-8 Drawing Three-Dimensional Figures..... | 185 |

Chapter 11 Measurement: Perimeter, Area, and Volume

| | |
|--|-----|
| 11-1 Perimeter | 187 |
| 11-2 Area of Parallelograms | 189 |
| 11-3 Problem-Solving Strategy: Make a Model..... | 191 |
| 11-4 Area of Triangles | 193 |
| 11-5 Problem-Solving Investigation: Choose the Best Strategy..... | 195 |
| 11-6 Volume of Rectangular Prisms | 197 |
| 11-7 Surface Area of Rectangular Prisms..... | 199 |

Homework Practice**5NS1.4***Prime Factors*

Tell whether each number is *prime*, *composite*, or *neither*. Find the prime factorization for each composite number.

1. 28

2. 36

3. 42

4. 11

5. 34

6. 7

7. 72

8. 23

9. 12

Spiral Review

Create a table to show the possible outcomes for the situation. Then, use the table to describe the probability of the event taking place.

- 10.** Sonja has a bag of canned food. She has two cans of peas, five cans of plum tomatoes, and one can of soup. She grabs a can out of the bag without looking. Describe the probability of Sonja grabbing a can of peas.

Problem-Solving Practice**5NS1.4***Prime Factors*

- There are 13 flavors at a local ice cream parlor. Is the number 13 a prime number or a composite number? If it is composite, write the number as the product of prime numbers.

- Martina ate 27 raisins. Is the number 27 prime or composite? If it is composite, write the number as the product of prime numbers.

- Sydney used divisibility rules to show that the number 640 is composite. What will she write when she writes the number as the product of prime numbers?

- Hope used a factor tree to factor the number 240. How many "branches" will be at the bottom of this factor tree? Write the number 240 as the product of prime numbers.

- Cruz and his friend, Penny, need to determine what numbers are prime and what numbers are composite for a homework assignment. Cruz says that the number 5 is a composite number because it has the factors 2 and 2.5. Explain what is wrong with his reasoning.

- Jesse drew a factor tree of a composite number and ended up with $4 \times 4 \times 5 \times 5 \times 3$ as the prime factorization. Explain what is wrong with this factorization. What is the correct prime factorization? What is the composite number that was factored?

Homework Practice**5NS1.3, 5NS1.4***Powers and Exponents***Complete the table.**

| | Exponent | Product |
|------------|-----------------|--------------------------------|
| 1. | 6^2 | |
| 2. | | 5×5 |
| 3. | 4^4 | |
| 4. | | $2 \times 2 \times 2 \times 2$ |
| 5. | 3^3 | |
| 6. | 6^2 | |
| 7. | | $4 \times 4 \times 4$ |
| 8. | | 3×3 |
| 9. | 2^3 | |
| 10. | | $5 \times 5 \times 5$ |
| 11. | | $7 \times 7 \times 7$ |
| 12. | 8^3 | |

Spiral Review**Find the prime factorization of the composite numbers.**

13. 75

14. 77

15. 42

Tell whether each number is *prime*, *composite*, or *neither*.

16. 17

17. 25

18. 44

19. 7

20. 31

21. 0

Problem-Solving Practice**5NS1.3, 5NS1.4***Powers and Exponents*

1. Lou wrote 3^4 in standard form. What was the number?

2. Heidi's family drove 1,000 mi on vacation. Write this number using a base and an exponent. Use 10 as the base.

3. Halle's family is buying new carpet for her bedroom. The room is 4 yards long and 4 yards wide. Write the area using a base and an exponent. Remember that area is calculated by multiplying the length times the width.

4. Lupe emptied her bank and has 144 pennies and 121 nickels. Write each of these numbers using a base and an exponent. For the pennies use 12 as the base. For the nickels use 11 as the base.

5. For a punch bowl, Carin needs a block of ice with a volume of at least 125 cubic inches. She has a cube of ice that is five inches on each side. Write the volume of the cube using a base and exponents. Then write it in standard form. Is the block of ice big enough? Remember that volume is calculated by multiplying length times width times height.

6. Very large and very small numbers in science are often written using bases and exponents. For example, the sun is approximately 1.5×10^8 km from Earth. Write the distance in standard form.

Homework Practice**4AF1.2***Order of Operations***Find the value of each expression.**

1. $2 \times (4 + 7) - 6$ _____

2. $10 \times (6 - 3) \div 15$ _____

3. $15 \div 3 + 16 \times (9 - 5)$ _____

4. $66 \div 11 + 3$ _____

5. $13 + 5^2 \times (8 - 3)$ _____

6. $18 - 3^2 + (9 - 0)$ _____

7. $27 \div 3^2 + (38 - 15)$ _____

8. $26 + 6^2 \times 4$ _____

9. $8 \div (20 - 16) + 3^2$ _____

10. $7 \times 6 \div 2 + (9 - 4)$ _____

11. $22 \times 4 \div 4 - 4^2$ _____

12. $8 + 32 \times (20 - 10)$ _____

Spiral Review**Write each product using an exponent. (Lesson 1-2)**

13. $4 \times 4 \times 4$ _____

14. $5 \times 5 \times 5 \times 5$ _____

15. 8×8 _____

16. $3 \times 3 \times 3$ _____

Write each power as a product of the same factor. Then find the value of the following.

17. 7^3 _____

18. 6^2 _____

19. 4^2 _____

20. 2^3 _____

21. 3^5 _____

22. 5^4 _____

Problem-Solving Practice**4AF1.2***Order of Operations*

1. Ted evaluated the expression $2 + 4 \times 6$. What was his answer?

3. Francisco wrote the number 3×10^2 in standard form. His answer was 900. What mistake did he make in order of operations?

What is the correct answer?

5. Create an expression whose value is 12. It should contain four numbers and two different operations.

2. Frank evaluated the expression $8^2 - (2 \times 6 + 3)$. What was his answer?

4. Glenn ate 2 apples a day for a week. In addition to the apples, he ate 3 pears during the week. Write the expression that shows how many pieces of fruit he ate during the week.

Evaluate the expression.

6. Keiko's class collected coins to buy food for a local family. When Keiko counted the coins, there were 27 quarters, 92 dimes, 140 nickels, and 255 pennies. Her teacher offered to add an amount to the total, equal to what the students collected. What expression did he use to find out how much money they had?

Evaluate the expression. _____

Homework Practice**5MR1.1, 4NS3.4***Problem-Solving Investigation***Use the four-step plan to solve each problem.**

1. A train left the station at 12:45. It traveled 455 miles in 7 hours. How many miles did it travel in each hour?

2. The Delgados are buying a pool that is 30 feet x 30 feet for \$1,188. They plan to pay in 12 equal payments. Find the amount of each payment.

3. After shopping for school supplies, Martin came home with \$4. He bought a pack of pens for \$6, a calculator for \$12, and a notebook for \$3. How much money did he start with?

4. Julio increases the laps he runs by three laps each day. If he begins on Monday running 4 laps, how many laps will he run on Wednesday at his current rate?

Spiral Review**Find the value of each expression. (Lesson 1-3)**

5. $15 - 2^3 \div 4$

6. $22 - 17 + 8$

7. $23 + 4^2 \div 2$

8. $64 - 12 + 7$

Homework Practice**5AF1.2***Algebra: Variables and Expressions***Evaluate each expression if $m = 3$ and $n = 15$.**

1. $25 - n$

2. $2m - 4$

3. $3n + m$

4. $n - 3$

5. $60 \div n$

6. $2m + n$

7. $2n - m$

8. $6m + 3$

9. $n - 2m$

10. $3m + n$

11. $4n + m$

12. $20 - n$

Evaluate each expression if $a = 2$, $b = 12$, and $c = 8$.

13. $a^2 + 2b$

14. $2c - 3$

15. $b + 3a$

16. $2b + 6$

17. $8a - b$

18. $8c - b$

Spiral Review**Find the value of each expression. (Lesson 1-4)**

19. $6 + 6 \times 3$

20. $40 \div 2 \times 5$

21. $18 + 4 - 8$

22. $18 - 2^3 + 1$

23. $139 - 3^3$

24. $5 + 6 \times 7$

Problem-Solving Practice**5AF1.2***Algebra: Variables and Expressions***Solve.**

1. Jaynee's friends ate 4 apples more than her family ate. Write an expression for how many apples Jaynee's friends ate.
2. Ian walked 5 blocks home from school. His friend Kim walked x blocks farther. Write an expression for how far Kim walked.

3. Carmen took her newspapers and aluminum cans to the recycling center. She weighed everything and found that she had 24 pounds more newspapers than cans. Write an expression for the weight of the newspapers, using c as a variable. _____
4. Hannah's grade on her last math test was 4 points less than Mark's grade. Write an expression for Hannah's grade, using m as a variable.

Find the value of the expression if $c = 12$.

Find the value of the expression if $m = 92$.

5. Ron made cookies for the fair. His sister made candy. Four cookies were packaged together, and 6 pieces of candy were packaged together. There were 6 more packages of cookies than p packages of candy. Write an expression for the number of packages of cookies. _____
6. Michael went to the water park. He spent 2 hours longer on the water slides than he did in the wave pool. If t represents the hours on the water slides, write an expression for the time he spent in the wave pool. _____

Find the value of the expression if $p = 8$. _____

Find the value of the expression if $t = 4$. _____

How many cookies and pieces of candy were taken to the bake sale?

How much time did he spend at the water park? _____ hours

_____ cookies

_____ pieces of candy

Homework Practice**5AF1.2, 5AF1.5***Algebra: Functions***Complete each function table.**

1.

| Input (x) | Output ($x - 3$) |
|---------------|--------------------|
| 5 | |
| 8 | |
| 4 | |

2.

| Input (x) | Output ($3x$) |
|---------------|-----------------|
| 4 | |
| 2 | |
| 9 | |

Find the rule for each function table.

3.

| Input (x) | Output |
|---------------|--------|
| 4 | 8 |
| 3 | 6 |
| 12 | 24 |

4.

| Input (x) | Output |
|---------------|--------|
| 7 | 2 |
| 15 | 10 |
| 25 | 20 |

5.

| Input (x) | Output |
|---------------|--------|
| 18 | 6 |
| 27 | 9 |
| 33 | 11 |

6.

| Input (x) | Output |
|---------------|--------|
| 10 | 50 |
| 12 | 60 |
| 35 | 175 |

Spiral Review (Lesson 1-5)7. Evaluate $13 + a$ if a is 7.

8. Evaluate $x - y$ if x is 87 and y is 78.

Evaluate each expression if $a = 6$ and $b = 10$.9. $b - a$

10. $b \times a$

Problem-Solving Practice**5AF1.2, 5AF1.5***Algebra: Functions*

| | |
|--|---|
| <p>1. DRAGONS The Luck Dragons that live in the Enchanted Forest weigh $4x$ pounds when they are x years old. Write a function table that can be used to find the weights of 6-year old, 8-year old, and 10-year old Luck Dragons.</p> | <p>2. ROLLER COASTER Twelve people are able to ride the Serpent of Fire roller coaster at one time. Write a function table that shows the total number of people that have been on the roller coaster after 1, 2, 3, and 4 rides if the roller coaster is full each time.</p> |
| <p>3. MOVIES At the local movie theater it costs \$10.00 for 2 students to see a movie. It costs \$15.00 for 3 students, and it costs \$20.00 for 4 students. Let the number of students be the input. What is the function rule that relates the number of students to the cost of tickets?</p> <p>_____</p> | <p>4. HOMEWORK At Elmwood Middle School, sixth graders spend 1 hour every night doing homework. Seventh graders spend 2 hours, and eighth graders spend 3 hours. Let the students' grade be the input. What is the function rule between the students' grade and the amount of time the students spend on homework every night?</p> <p>_____</p> |
| <p>5. BEADS A bead shop sells wooden beads for \$3 each and glass beads for \$7 each. Write a function rule to represent the total selling price of wooden (w) and glass (g) beads.</p> <p>_____</p> | <p>6. Use the function rule in Exercise 5 to find the selling price of 20 wooden beads and 4 glass beads.</p> <p>_____</p> |

Homework Practice**5MR2.6, 4NS2.1***Problem-Solving Strategy***Use the guess-and-check strategy to solve.**

1. Jamal is thinking of four different numbers from 1 through 9 whose sum is 21. Find the numbers.

2. Mr. Thompson took his 5 children to the amusement park. Tickets for children 12 and older cost \$3.50. Tickets for children under 12 cost \$2.25. He spends a total of \$16.25. How many of his children are 12 and older?

3. A cabin has room for 7 campers and 2 counselors. How many cabins are needed for a total of 49 campers and 14 counselors?

Spiral Review**Solve. (Lesson 1-6)**

4. El Capitan, in California, is 3,600 feet high. Mt. Morgan is 13,748 feet, Arrowhead Peak is 4,237 feet, and Hawkins Peak is 10,024 feet. List the mountains by height from greatest to least.

5. A department store is deducting \$10 off the total purchase for shoppers from 6 A.M. to 7 A.M. Define a variable. Write a function rule that relates the final cost to the total purchase amount.

6. Sonia is buying peanuts for a party. She can buy them in bulk for \$4 a pound. Define a variable. Write a function rule that relates the total cost of the peanuts to the amount she buys.

Homework Practice**5AF1.1, 5AF1.2***Algebra: Equations***Solve each equation mentally.**

1. $4 + x = 12$ _____

2. $16 - p = 3$ _____

3. $15 \div b = 3$ _____

4. $8 = 4f$ _____

5. $10k = 50$ _____

6. $64 \div g = 8$ _____

7. $j - 14 = 6$ _____

8. $4s = 24$ _____

9. $18 \div t = 3$ _____

Spiral Review**Copy and complete each function table. (Lesson 1-7)**

10.

| Input (x) | Output ($x + 2$) |
|---------------|--------------------|
| 7 | |
| 9 | |
| 11 | |

11.

| Input (x) | Output ($x - 4$) |
|---------------|--------------------|
| 4 | |
| 7 | |
| 10 | |

Find the rule for each function table.

12.

| Input (x) | Output |
|---------------|--------|
| 4 | 7 |
| 6 | 9 |
| 9 | 12 |

13.

| Input (x) | Output |
|---------------|--------|
| 25 | 13 |
| 20 | 8 |
| 13 | 1 |

Problem-Solving Practice**5AF1.1, 5AF1.2***Algebra: Equations*

For Exercises 1–3, use the table that gives the average lengths of several unusual insects in centimeters.

| Insect | Length (cm) | Insect | Length (cm) |
|------------------|--------------------|-----------------|--------------------|
| Walking stick | 15 | Giant water bug | 6 |
| Goliath beetle | 15 | Katydid | 5 |
| Giant weta | 10 | Silkworm moth | 4 |
| Harlequin beetle | 7 | Flower mantis | 3 |

| | |
|--|--|
| <p>1. The equation $15 - x = 12$ gives the difference in length between a walking stick and one other insect. If x is the other insect, which insect is it?</p> <p>_____</p> | <p>2. The equation $7 + y = 13$ gives the length of a Harlequin beetle and one other insect. If y is the other insect, which insect makes the equation a true sentence?</p> <p>_____</p> |
| <p>3. Bradley found a silkworm moth that was 2 centimeters longer than average. The equation $m - 4 = 2$ represents this situation. Find the length of the silkworm moth that Bradley found.</p> <p>_____</p> | <p>4. A Monarch butterfly flies about 80 miles per day. So far it has flown 60 miles. In the equation $80 - m = 60$, m represents the number of miles it has yet to fly that day. Find the solution to the equation.</p> <p>_____</p> |
| <p>5. The nymphs of some cicadas can live among tree roots for 17 years before they develop into adults. One nymph developed into an adult after only 13 years. The equation $17 - x = 13$ describes the number of years less than 17 that it lived as a nymph. Find the value of x in the equation to tell how many years less than 17 years it lived as a nymph.</p> <p>_____</p> | <p>6. A harlequin beetle lays eggs in trees. She can lay up to 20 eggs over 3 days. After the first day, the beetle has laid 9 eggs. If she lays 20 eggs in all, how many eggs will she lay during the second and third days?</p> <p>_____</p> |

Homework Practice**5AF1.2, 5MG1.4***Algebra: Area Formulas***Solve.**

1. Find the area of a square with a side length of 14 inches.
- _____

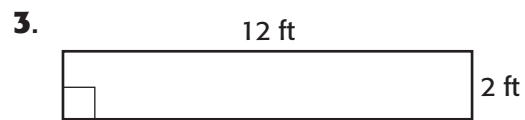
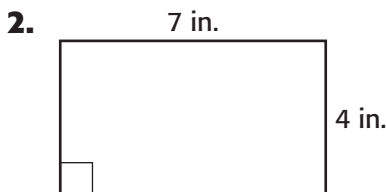
Find the area of each rectangle.**Find the area of the following squares and rectangles.**

4. a square with sides of 5 ft _____
5. a rectangle with a length of 13 inches and a width of 3 inches _____
6. a square with sides of 8 ft _____
7. a rectangle with a length of 14 inches and a width of 4 inches _____
8. a square with sides measuring 9 ft _____

Spiral Review**Solve each equation. (Lesson 1-8)**

9. $m + 15 = 27$ _____
10. $n + 35 = 42$ _____
11. $7b = 35$ _____
12. $g \div 3 = 4$ _____
13. $4p = 16$ _____
14. $12 \div c = 6$ _____
15. $y - 5 = 24$ _____
16. $r - 7 = 2$ _____

Problem-Solving Practice**5AF1.2, 5MG1.4***Algebra: Area Formulas***Solve.**

1. Felicia wants to clean the rug in her room. She buys carpet cleaner that will clean 40 ft^2 . Find the area of her rug. Will she have enough carpet cleaner?

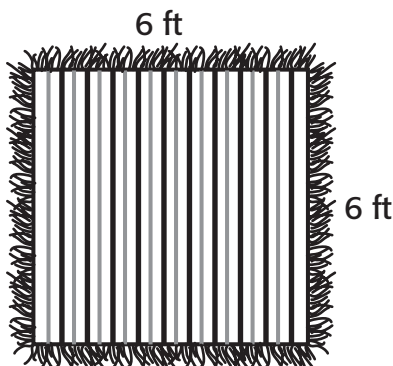

2. Lori wants to buy a flower mat that has seeds and fertilizer in it for her garden. She made a diagram of her garden. What is the area of the flower mat that she needs?

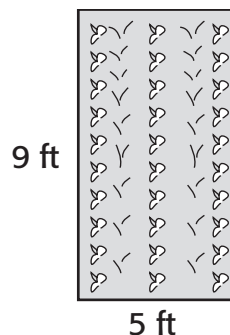

3. The playing area of a college's football field measures 100 yd by 53 yd . How much area does the football team have to play on?

4. Mr. and Mrs. Wilkes want to make a patio in their yard. The patio will be 15 ft long and 10 ft wide. Each patio tile covers 1 square ft and costs $\$2$. How much will they spend on patio tiles?

5. You have 100 ft of fencing to make a pen for your dog. You want your dog to have the biggest play area possible. What shape would you make the pen?

6. The Carsons are putting a rectangular swimming pool in their backyard. The pool will measure 20 ft by 12 ft . They plan to have a cement walkway around the pool, which should measure 4 ft wide. What is the area of the walkway?

Homework Practice**5AF1.3***Algebra: The Distributive Property***Find each product mentally. Use the Distributive Property.**

1. 10×41 _____

2. 5×32 _____

3. 3×57 _____

4. 18×3 _____

5. 14×5 _____

6. 2×26 _____

Rewrite each expression using the Distributive Property.

7. $5 \times (14 - 3)$ _____

8. $6 \times (9 + 2)$ _____

9. $7 \times (2 - 1)$ _____

10. $9 \times (3 + 4)$ _____

Rewrite each expression using the Distributive Property. Then evaluate.

11. $4 \times (8 + 2)$ _____

12. $8 \times (9 + 3)$ _____

13. $3 \times (12 + 4)$ _____

Spiral Review

14. Find the area of a square whose sides are 19 inches long. _____

Solve each equation mentally.

15. $a + 13 = 18$ _____

16. $43 - b = 24$ _____

17. $49 = 7x$ _____

18. $39 - k = 12$ _____

Problem-Solving Practice**5AF1.3***Algebra: The Distributive Property***Solve.**

1. Ray needs to multiply 5×26 to find the area of a rectangle. Fill in the blanks using the Distributive Property.

$$\begin{aligned} 5 \times 26 &= 5 \times (\underline{\quad} + 6) \\ &= (5 \times \underline{\quad}) + (5 \times 6) \\ &= \underline{\quad} + 30 \\ &= \underline{\quad} \end{aligned}$$

2. To multiply 8×14 , Jana used the distributive property. Fill in the blanks to show what she did:

$$\begin{aligned} 8 \times 14 &= 8 \times (10 + \underline{\quad}) \\ &= (8 \times \underline{\quad}) + (8 \times 4) \\ &= \underline{\quad} + 32 \\ &= \underline{\quad} \end{aligned}$$

3. Four friends went out to dinner. To cover dinner, tax, and tip, each person paid \$18. How much did they pay all together?
-

4. The fifth-grade classes at Wilcox Elementary School are reading books during the summer. There are 76 students, and each is supposed to read 4 books. How many books will the students read in all?
-

5. The four Boy Scout troops in Carver City sold 1,238 buckets of popcorn to raise money. If each bucket costs \$4, how much money did the troops raise?
-

6. James builds and sells furniture. Last month he sold 9 bookcases and 6 coffee tables. If each bookcase costs \$310, and each coffee table costs \$275, how much did James make?
-

Homework Practice**5SDAP1.2***Bar Graphs and Line Graphs*

1. Make a bar graph of the data in the table. Compare the number of students who chose pizza over tacos.

| Favorite Foods | |
|----------------|-----------|
| Food | Frequency |
| Tacos | 15 |
| Pizza | 25 |
| Hamburger | 10 |
| Salad | 20 |

Use the line graph at the right to answer the questions.

2. In which year did a can of Grandma's Soup cost the least?

3. Between which two years did the cost of a can of soup increase the most?

Average Cost of a Can of Grandma's Soup

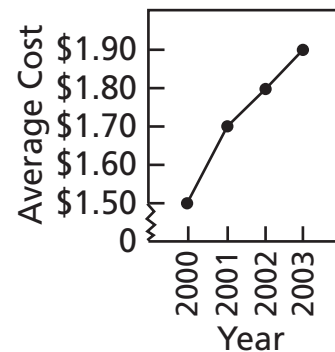
**Spiral Review**

Rewrite using the Distributive Property. Then evaluate.

4. $5 \times (3 + 2)$ _____

5. $3^2 + (9 - 3)$ _____

6. $(11 \times 2) + (2 \times 8)$ _____

7. $3 \times (24 \div 8) + 2$ _____

Problem-Solving Practice**5SDAP1.2***Bar Graphs and Line Graphs***Solve.**

1. Moesha volunteers at the zoo. She prepared a bar graph that shows the number of pounds of food eaten each day, by each animal. What information goes on the horizontal axis?

2. Dawn gathered information about the population of each county in her state. If she prepares a bar graph of this data, what information will be displayed on the vertical axis?

3. Tim lives in New York. He prepares a line graph that shows the amount of heating fuel used in his home for a year. Will the line rise, remain level, or fall between August and November?

4. In her social studies report, Suzanne included a bar graph that showed the populations of different Native American nations in 1800. The interval she used was 2,000 people. If one nation had a population represented by 2.5 intervals, how many members of this nation existed in 1800?

5. Jon makes a bar graph that shows the number of dogs owned by members of his class. If the smallest number is 1 and the largest number is 4, what interval should Jon use?

6. Anthony emptied his bank and made a bar graph of the numbers of each type of coin. The interval he chose was 5 coins. If the graph showed 5 intervals of quarters, 2 intervals of dimes, 3 intervals of nickels, and 10 intervals of pennies, what was the total amount of money in his bank?

Homework Practice**5SDAP1.4***Interpret Line Graphs*

The line graph below represents how much Daniel grew between 1998 and 2002. Use the line graph to answer the questions.

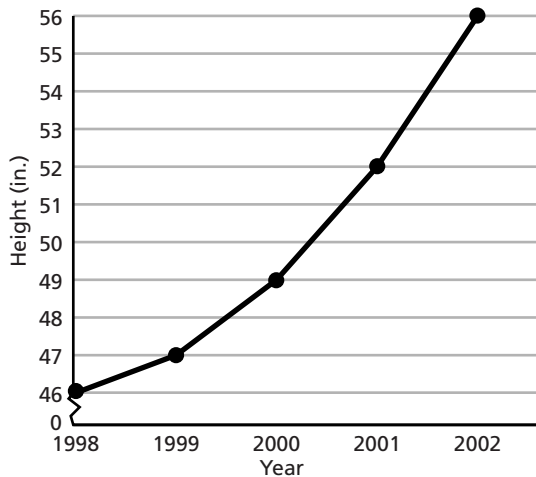

1. What does the horizontal axis represent?

2. What does the vertical axis represent?

3. Between which two years did Daniel grow the least?

4. How many inches did Daniel grow between 2000 and 2001?

Spiral Review

Use the bar graph below to answer the questions. (Lesson 2-1)

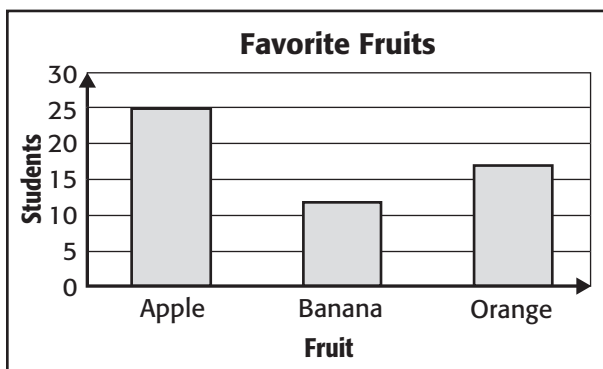

5. What does the vertical axis represent?

6. Which fruit is the students' least favorite?

7. How many more students preferred apples over oranges?

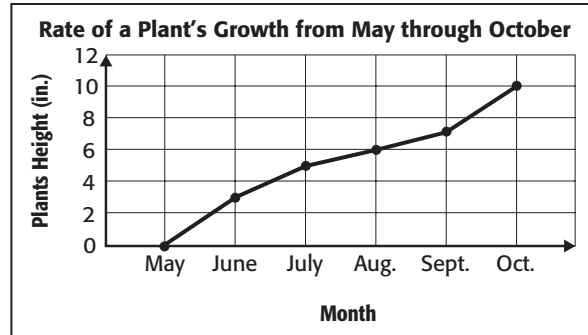
Problem-Solving Practice**5SDAP1.4***Interpret Line Graphs*

- Look at the graph. Between what month(s) did the plant experience the most growth?

- Between what month(s) was there the least amount of growth?

- If the line graph continued, based on the pattern of growth you see, how many inches do you think the plant would grow from October to November?

- Do you think this graph represents the pattern of growth for all plants? What are some pieces of information that graph does not tell you?

Homework Practice**5SDAP1.2***Histograms*

The histogram below represents the times and numbers of runners on the track at UCLA. Use the histogram to answer the questions.

1. About how many runners are on the track at UCLA between 7 P.M. and 10 P.M.?

2. About how many more runners are on the track from 7 A.M. to 10 A.M. than from 10 A.M. to 1 P.M.?

3. If you wanted to use the track at the time when it is least crowded, between what hours would you go?

Runners on UCLA Track

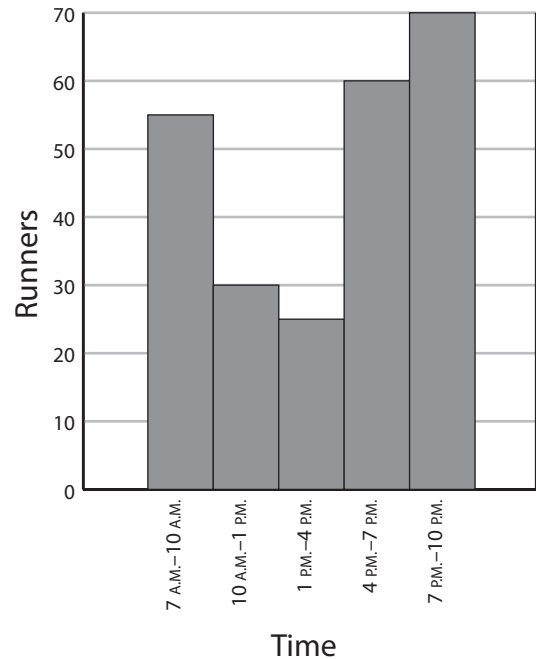
**Spiral Review**

Use the line graph to answer the questions.
(Lesson 2-2)

4. Describe the pattern or trend the graph illustrates.

Snowfall During Storm

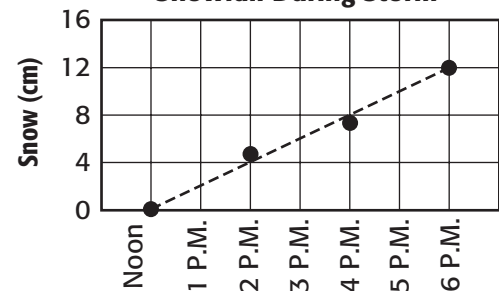

5. Between what two hours was there the greatest increase in snow fall, or did the snow fall the same amount during each of the hours shown on the graph?

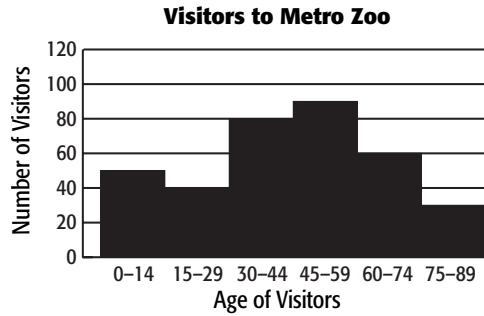
Problem-Solving Practice**5SDAP1.2***Histograms*

Use the data from the table for exercises 1 and 2.

- How many visitors to the zoo were between 15 and 29 years old?
- For what age group were there 60 visitors?

- How many more 30- to 44-years-old visitors were there than visitors 75 to 89 years old?
- How many visitors in all went to Metro Zoo on this day?

Make a histogram on a separate sheet of paper.

- The following numbers are the high temperatures for the month of April in Baltimore, Maryland. Make a histogram for the data.

45° 52° 49° 43° 55° 42° 58° 49° 50° 54° 47° 56°
 46° 62° 60° 54° 59° 45° 61° 58° 63° 53° 51° 59°
 48° 52° 55° 53° 50° 57°

- How many days in April was the temperature in Baltimore 49° or less? How many days was the temperature more than 53°?

Homework Practice**5SDAP1.2***Line Plots*

The line plot below represents the total number of runs scored by the 7 players on Tatiana's softball team this year. Use the information on the line plot to answer the questions.

1. Which player scored 4 runs this year?

2. Which players scored more than three runs this year?

3. How many more runs did Player 6 score than Player 1?

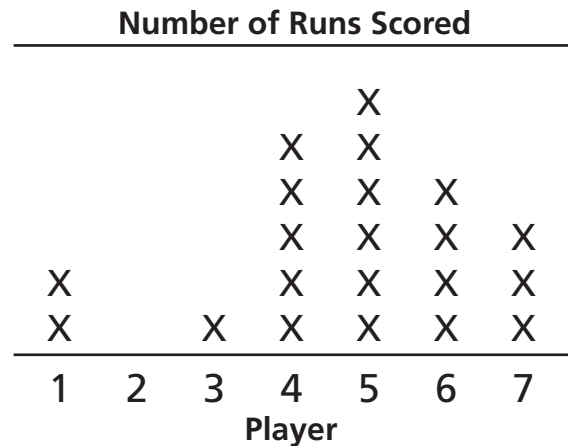
**Spiral Review**

Use the table below for exercise 4. (Lesson 2-3)

4. The data shows staggered start times of a marathon. Make a histogram of the data.

| Start Time | Number of Runners |
|-----------------------|-------------------|
| Between 8:00 and 8:02 | 45 |
| Between 8:02 and 8:04 | 58 |
| Between 8:04 and 8:06 | 78 |
| Between 8:06 and 8:08 | 56 |
| Between 8:08 and 8:10 | 33 |
| Between 8:10 and 8:12 | 13 |

Problem-Solving Practice**5SDAP1.2***Line Plots***Solve.**

1. Kyle surveyed his friends and found that 7 of them listen regularly to rock music, 5 listen to rap music, and 2 listen to country music. Which type of music would have the highest number in a frequency table?

2. Sean found that 6 of his classmates wore a size 5 shoe, 12 wore a size 6, 10 wore a size 7, and 2 wore an 8. On a line plot, which number would have the greatest number of Xs above it?

3. Deanna measured the length of a piece of wood three times. The measurements were 25.67 cm, 25.79 cm, and 25.71 cm. List the measurements in the order they would appear on a line plot.

4. Scott found that 12 of his classmates wore a size 5 ring, 9 wore a size 6, and 3 wore a size 7. On a line plot of this data, is the number of students or the ring size located by a number on the number line?

5. Laura kept a table of the daily temperatures during January in Minnesota. What changes might she have to make in a number line that starts at zero and goes to 20, so that it could be used to make a line plot of the temperatures?

6. Tyler planted 25 seedlings. One grew to 6 inches in height, 13 grew to 5 inches, 10 grew to 4 inches, and 1 grew to 3 inches. On a line plot of Tyler's data, which height would have the least number of Xs over it?

Homework Practice**5MR2.3, 5SDAP1.2***Problem-Solving Strategy***Solve. Use the *make a table* strategy.**

1. Maya has a list of her friends' number of CDs. How many more friends have from 21 to 30 than from 11 to 20?

| CDs | | | | |
|-----|----|----|----|----|
| 10 | 11 | 10 | 21 | 29 |
| 28 | 19 | 13 | 27 | 26 |
| 25 | 26 | 30 | 11 | 22 |
| 21 | 26 | 17 | | |

2. Hilda took a survey of her neighborhood to find out how many pets each family has. How many families have 2 or more pets?

| Number of Pets | | | | | | | | |
|----------------|---|---|---|---|---|---|---|---|
| 0 | 3 | 1 | 0 | 2 | 4 | 1 | 1 | 2 |
| 0 | 0 | 4 | 2 | 1 | 3 | 0 | 1 | 2 |
| 5 | 1 | 2 | 0 | 0 | 5 | 2 | 1 | 1 |

3. Steven took a survey of the building materials used to build the houses in his neighborhood. How many more houses are made of wood than of brick?

| Building Materials | | | | | | |
|--------------------|---|---|---|---|---|---|
| W | W | B | S | S | W | S |
| B | W | W | W | B | B | S |
| S | W | B | B | W | S | S |

W = wood

B = brick

S = aluminum siding

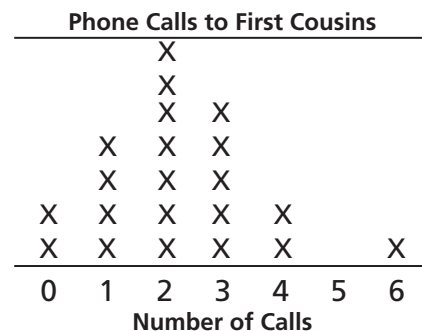
Spiral Review**Use the line plot for Exercises 4 and 5. (Lesson 2-4)**

4. What is the most popular number of calls?

5. What is the second least popular number of calls?

Homework Practice**5SDAP1.1***Mean***Find the mean of each data set.**

1. 40, 35, 45, 40, 30

2. 35, 20, 5, 10, 30

3. 33, 39, 3, 22, 3, 20

4. 14, 42, 10, 60, 46, 32

5. The Colombo family has 2, 4, 1, and 5 pairs of boots among them. What is the mean of the number of boots the Colombo family owns?

6. Julie has 13 cousins. Emily has 5, and Amber has 12. What is the mean of the number of cousins the girls have?

7.

| Team Member | Ryan | Oliver | Kyle | Sam | Manny |
|-------------|------|--------|------|-----|-------|
| Laps Run | 22 | 17 | 21 | 10 | 15 |

Spiral Review**Use the *make a table* strategy to solve. (Lesson 2-5)**

8. For breakfast the class had four choices from which to choose. Some chose scrambled eggs (S), some chose an omelet (O), some chose pancakes (P), while still others chose a breakfast burrito (B). The results are shown below.

P P B B S S O B S P B O P S P B P B S

How many people chose scrambled eggs as their breakfast?

Problem-Solving Practice**5SDAP1.1***Mean***Solve. Find the mean to the nearest whole number.**

1. Janice is selling cookies for her scout troop. One day she sold 10 boxes, the next day 15, the third day she sold 12, and on the fourth day she sold 13. How many does she need to sell on the 5th day to reach her goal of an average of 13 boxes a day?

2. Clarence counted birds for a science project in the park every day for a week. He noticed 4 cardinals on the first day, 3 on the second day, 6 on the third day, and none on the fourth day. What is the average number of cardinals during the 4 days?

3. Each of Tabitha's friends has pets. Billy has 3 rabbits, Terrence has 4 kittens, Sarah has 2 goldfish, and Brianna has 1 dog. What is the average number of pets Tabitha's friends own? Remember to round up to the nearest whole number.

4. Shelly had 4 friends come to her house to study one day after school. The next day 6 friends came over to study, the third day only 2 friends came over. What is the average number of people who came to Shelly's house?

5. Jason downloaded songs for his MP3 player every week for a month. One week he downloaded 15 songs, the second week he downloaded 12, the third week he downloaded 10, and the fourth week he downloaded 20. What is the average number of songs he downloaded each week?

6. Write a problem in which the mean of a set of data must be determined.

Homework Practice**5SDAP1.1***Median, Mode, and Range***For each data set, find the median, mode, and range.****22, 26, 19, 29, 23, 22, 39**

1. Median _____

2. Mode _____

3. Range _____

11, 13, 12, 8, 12,

4. Median _____

5. Mode _____

6. Range _____

34, 33, 39, 44, 52, 52, 11

7. Median _____

8. Mode _____

9. Range _____

\$3.25 \$4.35 \$3.50 \$4.25 \$3.35 \$3.50 \$3.50

10. Median _____

11. Mode _____

12. Range _____

Spiral Review**Find the mean. (Lesson 2-6)**

- 13.** In five days Jessica got 5 letters, 3 letters, 4 letters, and 2 letters, and 6 letters. What is the mean of letters Jessica received?
- _____

- 14.** Use the graph below to find the average number of fish caught.

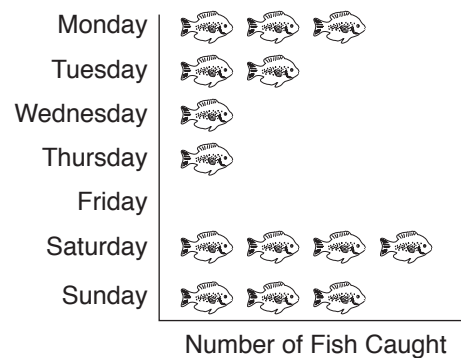

Problem-Solving Practice**5SDAP1.1***Median, Mode, and Range***Solve.**

1. A convenience store sold 5 bottles of Super Cola, 6 bottles of Citrus Surprise, and 2 bottles of Mark's Root Beer. What is the range of these data?

2. Bryan keeps score for the girls' basketball team. In the last game, Mary scored 12 points; Julia, 2 points; Heather, 5 points; Brittany, 10 points; Heidi, 7 points; and Michelle, 1 point. To the nearest tenth, what is the median?

3. Martin made 17 hits out of 51 times at bat in May. He made 12 hits out of 45 times at bat in June, and 14 hits out of 59 times at bat in July. To the nearest thousandth, what is his batting average at the end of July? To find a batting average, first find the total number of hits, and add a decimal point and three zeros to the right of the number (for example, 12.000). Divide this number by the total number of times at bat. Is a batting average a range, a mode, a median, or a mean?

4. Bonnie measured the high temperature for each day of the week. Her readings were 20°C, 22°C, 22°C, 20°C, 20°C, 24°C, and 25°C. What is the mode?

5. In science class, Rosa measured the distance traveled by a cart in 5 seconds. Her data are 4.6 ft, 2.3 ft, 6.9 ft, 4.4 ft, and 3.6 ft. What is the median?

6. Rita walks almost every day for exercise. One week she walked 9 blocks, 14 blocks, 10 blocks, 11 blocks, 18 blocks, and 15 blocks. What is the median distance she walked?

7. Mrs. Ramirez baked on five consecutive days for her school's bake sale. She baked 2 pies, 3 pies, 8 pies, 2 pies, and 6 pies. What is the mode of the number of pies Mrs. Ramirez baked?

8. Jake is practicing for a marathon. In the last month he has run 12 miles, 14 miles, 12 miles, 15 miles and 11 miles. What is the median distance he has run?

Homework Practice**5MR1.1, 4NS2.1***Problem-Solving Investigation***Extra or Missing Information****Solve or write *not enough information*.**

- Out of a class of 24 students, Timothy and 5 of his friends play baseball. A baseball team is made up of 9 players. How many more players do Timothy and his friends need to form a team?

- Donna took \$25.53 with her when she went shopping. She bought a bracelet for \$15.99 and a pair of earrings to match. How much money did she have left over?

- Connie took the train from her small town to a large city. She left at 1:00 P.M. and arrived at 4:23 P.M. The train cost \$14 plus \$0.10 a mile. How much did the train ride cost if she traveled 152 miles?

- Maria wants to make a cake for a family dinner. One cake will serve 10 people. Does she have enough cake to serve everyone?

- Lisa received tips during the holiday season from several of the customers on her newspaper route. There were 25 customers, and she received tips from 10 of them. Two customers gave her \$5, one customer gave her \$10, and five customers gave her \$1. What was the total amount she received?

- Nikolas is one of two halfbacks on a football team. His team scored 44 points during last week's game. Nikolas made one touchdown for 6 points and a safety for 2 points. If his team won last week's game by 14 points, how many points did Nikolas score?

Spiral Review**Find the median, mode, and range of the data set. (Lesson 2-7)****45, 49, 39, 45, 44, 64, 44, 41, 55**

7. Median: _____

8. Mode: _____

9. Range: _____

Homework Practice**5SDAP1.2***Selecting an Appropriate Display*

Select an appropriate type of display for data gathered about each situation.

1. comparing the costs of four bicycles

2. showing the prices of cookies during one year

3. the number of students in a school and their ages in equal intervals

4. the number of boys who attended Camp Green Tree each year from 2004–2006

5. comparing the populations of the largest cities in California

Spiral Review

Identify the missing information or extra information in each exercise. (Lesson 2–8)

6. Out of a class of 26 students, Brianne and her 3 friends play on a soccer team. If there are 7 other students on the team, how many total players are on the soccer team?

7. Pat had \$40 when he went shopping. He bought two pairs of socks at \$5 each, a belt for \$14, and a soda. How much money did he have left?

Problem-Solving Practice**5SDAP1.2***Selecting an Appropriate Display*

1. Raymond wants to know how many of each kind of sports jersey he owns. What graph would you use to best represent the following?

| Sports Jersey | Number of Jerseys |
|---------------|-------------------|
| Soccer | 3 |
| Football | 1 |
| Baseball | 4 |
| Basketball | 2 |
| Hockey | 5 |

2. Hannah wanted to spend less money on clothes. Graph the amount of money she spent during a 6-month period and whether she met her goal to spend less. Explain your choice of graph.

3.

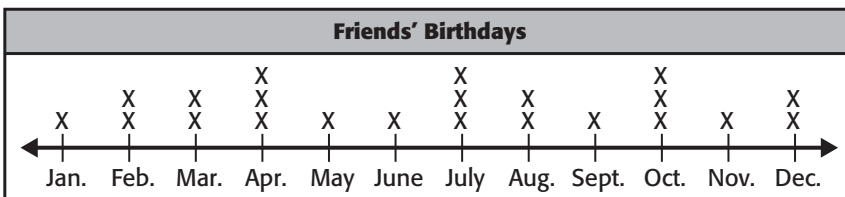

Explain why this graph is the best choice to show this information. How might a person use the information this graph provides?

Homework Practice**5NS1.5***Integers and Graphing***Write an integer to represent each piece of data.**

1. The temperature rose 5 degrees.

2. Greg lost \$4 on the way to school.

3. Justine grew 2 inches last year.

4. Robby withdrew \$10 from the bank.

Graph each integer on a number line.

- 5.
- -3

- 6.
- $+4$

- 7.
- -6

Spiral Review**Select an appropriate display for data gathered about each situation. Explain your reasoning. (Lesson 2-9)**

8. the number of push-ups Carlos has done each day during his training for football

9. the miles of coastline of all of the westernmost California counties

10. the number of points Darren scored for his basketball team each year he played

Problem-Solving Practice**5NS1.5***Integers and Graphing***Solve.**

1. Federico located -5 on a number line. Marge located the opposite. What number did Marge locate?

2. Valerie lives in a small community in California. The elevation of this community is 300 feet below sea level. Write an integer to represent this elevation.

3. Lan keeps temperature records for the weather station at her school. She recorded a low temperature of 15°F on Monday. The low temperature on Tuesday was seven degrees lower than the low temperature on Monday. The low temperature on Wednesday was ten degrees less than the temperature on Tuesday. What was the low temperature on Wednesday?

4. On the first play, a football team moved the ball -6 yards. On the next play, the team moved the ball exactly the opposite. Did the team gain or lose yards on the second play? How many yards?

5. The temperature on a cold day in Columbus, Ohio, is four degrees below zero. Where would this temperature be found on a number line?

6. Simon lives in a cold climate. He measures the low temperatures for one week. These temperatures are 0°F , -2°F , 1°F , 4°F , -6°F , -7°F , and 2°F . Write these numbers from least to greatest.

7. Adam earned \$45 at an after-school job. He received an allowance of \$10. He went to the store with his mother and wanted to purchase a CD player for \$60. He did not have enough money with him, so his mother loaned him enough to make his purchase. He will pay her back. Write an integer to represent the amount of money Adam had to borrow.

8. The low temperature on Saturday was -5°F . The low temperature on Sunday was -9°F . Which day was colder?

Homework Practice**5NS1.5***Representing Decimals*

Graph each decimal in the approximate position on the number line.



1. -0.3

2. -1.05

3. 4.6

4. 0.80

5. 3.00

6. -4.95

Write the letter that represents each decimal on the number line.

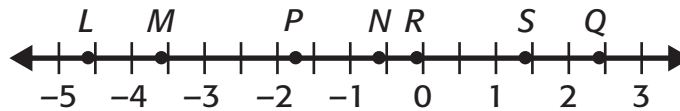

7. -0.6 _____

8. -3.6 _____

9. 1.40 _____

10. -0.06 _____

11. 2.4 _____

12. -1.75 _____

Spiral Review

Write an integer to represent each piece of data.

13. Sylvia is 55 inches tall. _____

14. Jeremy lost \$8. _____

15. A basketball has a diameter of 10 inches. _____

16. Tanya withdrew \$15 from the bank. _____

Problem-Solving Practice**5NS1.5***Representing Decimals***BASEBALL** For Exercises 1–4, use the table.

The table shows lifetime batting averages for leading baseball players.

| Lifetime Batting Averages for Leading Players | | |
|---|-------------------|-----------------|
| Player | Team | Batting Average |
| Tony Gwynn, Jr. | Milwaukee Brewers | 0.294 |
| Derek Jeter | New York Yankees | 0.341 |
| Ichiro Suzuki | Seattle Mariners | 0.319 |
| Mike Piazza | San Diego Padres | 0.277 |
| Chipper Jones | Atlanta Braves | 0.318 |

Source: mlb.com

| | |
|--|---|
| 1. Write Mike Piazza's batting average in word form. | 2. Which digit is in the thousandths place of each player's batting average? |
| 3. What is the batting average for the New York Yankees player in expanded form? | 4. Which player's average has a 4 in the hundredths place? |
| 5. BUILDING When measuring board footage for some exotic woods, a carpenter must use 1.25 for thickness rather than 1 in her calculations. Write 1.25 in expanded form. | 6. TRAVEL The summer camp Jason attends is exactly four hundred twenty-three and four tenths of a mile from his home. Write <i>four hundred twenty-three and four tenths</i> in standard form. |

Homework Practice**4NS1.2***Comparing and Ordering Whole Numbers and Decimals***Use $>$, $<$, or $=$ to compare each pair of decimals.**

- | | |
|----------------------------|-----------------------------|
| 1. 0.788 ● 0.778 _____ | 2. 1.1 ● 1.10 _____ |
| 3. 4.052 ● 4.05 _____ | 4. 0.0549 ● 0.549 _____ |
| 5. 4.563 ● 0.4563 _____ | 6. 0.00783 ● 0.00837 _____ |
| 7. 9.34132 ● 9.31432 _____ | 8. 7.341 ● 70.041 _____ |
| 9. 0.30 ● 0.3000 _____ | 10. 1.8091 ● 1.8901 _____ |
| 11. 8.34 ● 8.43 _____ | 12. 0.23441 ● 0.34421 _____ |
| 13. 0.0120 ● 0.012 _____ | 14. 2.5038 ● 2.3058 _____ |

Order each set of decimals from *least to greatest*.

15. 2.654, 2.564, 2.0564, 2.465 _____
16. 1.11, 0.111, 1.01, 1.0011 _____

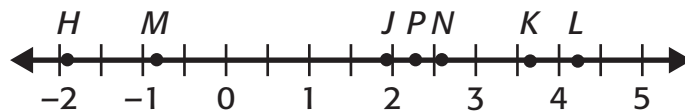
Spiral Review**Write the letter that represents each decimal on the number line.
(Lesson 3-1)**

- | | |
|----------------|----------------|
| 17. -0.8 _____ | 18. 2.6 _____ |
| 19. 1.9 _____ | 20. -1.9 _____ |

Problem-Solving Practice**4NS1.2***Comparing and Ordering Whole Numbers and Decimals***Solve.**

1. The table shows the heights of four students. Arrange the students in order from shortest to tallest.

| Student Heights | |
|-----------------|-------------|
| Name | Height (cm) |
| Kim | 56.03 |
| Alexa | 56.3 |
| Roy | 56.14 |
| Tom | 57.1 |

-
2. Two newborn babies are weighed at the hospital. The baby girl weighs 7.25 lbs, and the baby boy weighs 7.3 lbs. Which baby weighs more?
-
3. Three of the tallest mountains in the world are Nanga Parbat (Pakistan), Dhaulagiri (Nepal), and Annapurna (Nepal). They measure 26,660 feet, 26,810 feet, and 26,504 feet, respectively. Which of the three mountains is the shortest?
-
4. The four fastest times in a race were 9.789 seconds, 10.01 seconds, 9.76 seconds, and 9.8 seconds. Order these times from slowest to fastest.
-
5. George was weighed at the doctor's office. The scale read 67.20 pounds, but the doctor wrote 67.2 pounds on George's chart. Did the doctor make a mistake?
-
6. Write all possible missing digits that make the sentence $49.76 > 49.\square 6$ true.
-
7. The three fastest times in the past 20 years for the girls' 200-meter run at Clarksville Elementary School are 28.42 seconds, 27.97 seconds, and 27.93 seconds. At yesterday's track meet, Claire ran 27.99 seconds and Leslie ran 27.51 seconds. Should either girl's time be included in the list of top 3 times?
-
8. Lauren spent \$3.26 for lunch on Tuesday. She spent \$1.98 on Wednesday and \$2.74 on Thursday. Order the prices of her lunches from greatest to least.
-

Homework Practice*Rounding Whole Numbers and Decimals***Round each decimal to the indicated place-value position.**

- | | |
|-------------------------------|-----------------------------|
| 1. 1.583; ones _____ | 2. 67.095; tenths _____ |
| 3. 5.67; ones _____ | 4. 7.123; hundredths _____ |
| 5. 0.069; hundredths _____ | 6. 0.254; tenths _____ |
| 7. 569.8508; hundredths _____ | 8. 13.47; tens _____ |
| 9. 0.7010; thousandths _____ | 10. 10.89; tenths _____ |
| 11. 7.1385; thousandths _____ | 12. 0.571; hundredths _____ |
| 13. 215.073; hundreds _____ | 14. 105.148; tenths _____ |

Spiral Review**Use $>$, $<$, or $=$ to compare each pair of decimals. (Lesson 3-2)**

- | | |
|--------------------------|---------------------------|
| 15. 0.022 ● 0.0220 _____ | 16. 3.6723 ● 3.6273 _____ |
| 17. 5.62 ● 5.626 _____ | 18. 8.6932 ● 8.9623 _____ |

Order each set of decimals from *least* to *greatest*.

19. 5.6, 5.606, 5.06, 5.66 _____
20. 0.333, 3.33, 3.0033, 3.03 _____
21. 3.4, 3.14, 3.04, 3.44 _____
22. 8.20, 8.02, 8.63, 8.707 _____

Problem-Solving Practice**5NS1.1***Rounding Whole Numbers and Decimals***For Exercises 1 and 2, use the table.**

The table shows the number of people in the United States per square mile.

| U.S. Population | |
|-----------------|---|
| Year | Number of people per square mile of land area |
| 1970 | 57.4 |
| 1980 | 64.0 |
| 1990 | 70.3 |
| 2000 | 79.6 |

1. Round the decimal for the number of people per square mile in 2000 to the nearest tens. Then round it to the nearest ones. _____
2. Round the decimal for the number of people per square mile in 1970 to the nearest tens. Then round it to the nearest ones. _____

For Exercises 3–7, use the following information.

The Everglades National Park gets an average of 59.10 inches of rainfall a year. It had 1.181351 million visitors in 2004, and its budget for 2003 was \$13.958 million.

3. How much rain does the Everglades National Park receive each year rounded to the nearest inch? _____
4. How many visitors did the park have rounded to the nearest tenth of a million? _____
5. How many visitors did the park have rounded to the nearest ten-thousandth of a million? _____
6. What is the budget to the nearest million? _____
7. What is the budget to the nearest hundredth of a million?

8. SNOWBOARDING Mike, Jake, and Aaron are buying snowboards. Mike is getting his snowboard on sale for \$219.49. Jake's costs \$279.97. Aaron's costs \$234.95. Round each snowboard price to the nearest dollar. _____

Homework Practice**5MR2.4, 5MG1.4***Problem-Solving Strategy***Solve. Use the *logical reasoning* strategy.**

1. Mika and Pazi each think of a number. Mika's number is 7 more than Pazi's number. The sum of the two numbers is 49. What is Pazi's number?

2. A park has an area of 64 square meters and a perimeter of 40 meters. Find the length and width of the park.

3. Breanna has quarters, dimes, and nickels in her purse. She has 3 fewer nickels than dimes, but she has 2 more nickels than quarters. If Breanna has 2 quarters, how much money does she have?

4. Jennifer, Tara, and Brooke are waiting in a line. Brooke is not first in line. Jennifer is behind the oldest in line. Brooke is behind Jennifer. List the girls in order from first to last.

Spiral Review**Round each decimal to the indicated place-value position. (Lesson 3-3)**

5. 2.084; tenths _____

6. 435.1075; tens _____

7. 0.304; hundredths _____

8. 62.5706; thousandths _____

Homework Practice**5NS1.1***Estimating Sums and Differences*

1. $5.30 + 1.76 + 4.079$ _____

2. $2.341 - 1.51$ _____

3. $100.38 - 16.653$ _____

4. $2.462 + 6.90001 + 3.189$ _____

Estimate using clustering.

5. $3.81 + 4.4913$ _____

6. $\$6.46 + \5.50 _____

7. $1.62 + 2.40351 + 2.0099$ _____

8. $\$4.82 + \$5.31 + \$5.01$ _____

Estimate using front-end estimation.

9. $60.032 + 5.2902$ _____

10. $\$10.84 - \8.31 _____

11. $\$12.53 + \$2.49 + \$4.07$ _____

12. $142.6447 - 44.9204$ _____

Use the lunch menu for exercises 13–14.

13. Malcolm buys a taco and milk. About how much money does he spend?
-
- _____

14. Susan buys a salad and two hamburgers. About how much does she spend?
-
- _____

| Lunch Menu | |
|------------|--------|
| Item | Price |
| Milk | \$0.40 |
| Hamburger | \$1.25 |
| Salad | \$0.95 |
| Taco | \$1.49 |
| Pudding | \$0.70 |

Spiral Review**Solve. Use the *logical reasoning* strategy. (Lesson 3-4)**

15. Megan has twice as many cookies as her brother Rick. Megan gives Rick 5 cookies. Now Rick and Megan have the same number of cookies. How many cookies did Rick have to begin with?
-
- _____

Problem-Solving Practice**5NS1.1***Estimating Sums and Differences***Solve.**

1. The road Sheryl takes to school is 29.76 mi long. What is this distance to the nearest whole mile?

2. Mohammed walked 8.7 blocks to school and the same distance home. Estimate the number of blocks he walked.

3. A serving of crackers contains 169 calories, 82 of which come from fat. To the nearest ten, estimate the number of calories that do not come from fat.

4. Bethany made purchases of \$10.34 and \$27.60 at the store. Estimate what she spent to the nearest dollar.

5. Yat is trying to win a contest by guessing the number of marbles in a jar. Looking at the jar, he estimates that each layer contains 17 marbles, and that there are 12 layers in the jar. Estimate the number of marbles in the jar to the nearest ten.

6. For his lawn-mowing service, Gaspar has three gasoline cans. One can contains 5.17 gallons of gasoline; one contains 4.96 gallons; and the third, 4.23 gallons. To the nearest whole gallon, estimate the total amount of gasoline he has.

7. Juanita and Jim each think of a number. Juanita's number is 83 more than Jim's number. Jim's number is 113. Estimate the sum of Jim's and Juanita's numbers.

8. Lucia has 38 peanuts in a bowl. Emily has 51 peanuts. Estimate the total number of peanuts that the girls have to the nearest 10.

Homework Practice**5MR2.6, 5NS1.1***Problem-Solving Investigation*

For each problem, determine whether you need an estimate or an exact answer. Then solve.

1. Judi is shopping for school supplies. She buys a binder for \$1.05, a 3-hole punch for \$2.39, and a pack of pencils for \$0.88. How much money did Judi spend?
- _____

2. Dane has 35 pairs of socks. He divides them among three drawers. About how many pairs of socks are in each drawer?
- _____

Use the table for exercises 3 and 4.

Gregoria is reading a 100-page book. The table shows how many pages she read each night this week.

3. About how many pages has Gregoria read?
- _____

| Day | Pages |
|-----------|-------|
| Monday | 32 |
| Tuesday | 26 |
| Wednesday | 13 |
| Thursday | 18 |

4. How many pages must Gregoria read on Friday if she wants to finish the book?
- _____

5. A total of 12 students each donated 15 cans of food to charity. Their goal was to donate a total of 170 cans of food. Did they meet their goal?
- _____

Spiral Review

Estimate using rounding. (Lesson 3-5)

6. $5.193 + 2.560 + 3.088$ _____

7. $9.8015 - 4.763$ _____

Estimate using clustering.

8. $4.59 + 5.4641$ _____

9. $\$7.68 + \7.55 _____

Homework Practice**5NS2.1***Adding and Subtracting Decimals***Find each sum.**

1. $1.546 + 0.07$ _____

2. $75.4 + 0.5919$ _____

3. $\$100.80 + \5.87 _____

4. $3.72 + 6.0064$ _____

5. $0.802 + 0.4581$ _____

6. $4.3 + 0.1748$ _____

7. $\$0.35 + \0.54 _____

Find each difference.

8. $\$11.11 - \4.88 _____

9. $5 - 4.825$ _____

10. $10 - 3.485$ _____

11. $16.2445 - 3.77$ _____

12. $6.5 - 3.001$ _____

13. $3.48 - 3.039$ _____

14. $2.1 - 1.34$ _____

Spiral Review

**Determine whether you need an estimate or an exact answer.
Then solve. (Lesson 3-6)**

Tickets to an amusement park cost \$39.95.
Mary is saving her allowance in order to buy a ticket.
The table shows how much money she has saved over
the past four months.

| Money | Savings (\$) |
|--------|--------------|
| May | 7.78 |
| June | 8.43 |
| July | 7.80 |
| August | 9.32 |

15. About how much money has Mary saved?

16. How much more money must Mary save in order to buy the ticket?

Problem-Solving Practice**5NS2.1***Adding and Subtracting Decimals***Solve.**

1. If Tina had 4.6 gallons of water in one bucket and 2.3 gallons in another bucket, how many gallons did she have altogether?

2. Marcos had \$10.52 when he went to the store. If he bought a book for \$6.39, how much money did he have left over?

3. Kim threw the discus 9.54 m. If the record for her school is 15.23 m, how much farther did she need to throw the discus to tie the school record?

4. Noah measured the length of three pieces of cloth. The measurements were 4.29 ft, 3.6 ft, and 2.34 ft. What was the total length of the three pieces of cloth?

5. Hannah was subtracting the number 4.576 from the number 9.2. Her answer was 4.776. Is this answer correct? If not, what is the correct answer?

6. Robert bought one 4.5-lb bag of dog food for \$3.89, a 7.5-lb bag of cat food for \$6.69, and two 2.3-lb bags of birdseed for \$1.89 each. How much did he pay for the animal food?

7. Doreen has \$20. She wants to buy a pair of earrings that costs \$7.58 and a necklace that costs \$13.36. Does Doreen have enough money? Explain your reasoning.

8. Marcos is happy because it has snowed in his town for three straight days. On Monday it snowed 3.56 inches. On Tuesday it snowed 4.359 more inches. On Wednesday it snowed 3.07 more inches. What was the total snowfall over the three days?

Homework Practice**6NS2.4***Greatest Common Factor***Identify the common factors of each set of numbers.**

1. 1, 4, 6, 8, 32 _____

2. 1, 3, 6, 12, 24 _____

Find the GCF of each set of numbers.

3. 5, 45 _____

4. 6, 42 _____

5. 12, 24, 60 _____

6. 4, 16, 32 _____

7. 15, 30, 60 _____

8. 9, 18, 27 _____

Solve.

9. Janice has three CD storage cases that can hold 18, 36, and 64 CDs. The cases have sections holding the same number of CDs. What is the greatest number of CDs in a section?

10. Packages of cheese are sold in sealed containers that have sections holding the same number of slices. The containers can hold 6, 12, and 24 sections. What is the greatest number of sections in each container? _____

Spiral Review**Find each sum or difference. (Lesson 3-7)**

11. $6.2 + 8.5$ _____

12. $1.23 + 3$ _____

13. $65.2 + 38.11$ _____

14. $58.67 + 28.72$ _____

15. $0.856 + 14$ _____

16. $6.7 - 2.4$ _____

17. $18.87 - 3.44$ _____

18. $56 - 12.38$ _____

19. $76 - 44.92$ _____

20. $24.33 - 3.88$ _____

Problem-Solving Practice**6NS2.4***Greatest Common Factor***Solve.**

1. Aaron played 24 softball games, and Marianne played 20 games. What is the greatest common factor of these numbers?

2. Ellen is making flower arrangements. She has 48 carnations and 40 roses. What is the greatest number of identical arrangements she can make using all the flowers?

3. Mrs. Ellis' class contains 30 students. Mr. Hernandez' class contains 25 students. They want equal-sized science groups, so that they can share supplies. What is the largest number of students that can be in a group?

4. Kendall is making holiday cookies. He made 48 sugar cookies and 36 chocolate chip cookies. What is the greatest number of bags of cookies he can make if each bag has the same amount of each kind of cookie?

5. John placed 128 beads in equal rows to make an art project. His friend Mark used 125 beads to make a similar project. Is it possible for their projects to contain the same number of beads in a row? Explain your answer.

6. Erin's parents are starting an orchard. They bought 250 apple trees, 125 peach trees, and 175 pear trees. They want to plant the same number of trees in each row. They want only one type of tree in a row, and they want to plant all the trees. What is the greatest number of trees they can plant in a row?

Homework Practice**5MR.1.1, 5NS1.4***Problem-Solving Strategy***Make an organized list.****Solve. Use the *make an organized list* strategy.**

1. Andy only knows three people in the study hall. Desks are arranged in pairs. How many possible ways can Andy sit next to someone he knows?
-

2. Russ has to go to the office, the school store, and the water fountain. How many different ways can Russ make the stops?
-

3. Linda has black pants and a pair of jeans, black and red shoes, a red striped jersey and a white jersey. How many outfits can she make if she always wears a jersey, pants, and shoes?
-

4. How many different ways you can write the product of the prime factors of 24?
-

Spiral Review**Identify the common factors of each set of numbers. (Lesson 4-1)**

5. 1, 5, 25, 35 _____

6. 1, 18, 32, 36, 44 _____

Find the GCF of each set of numbers.

7. 8, 72 _____

8. 7, 56 _____

9. 3, 9, 12 _____

10. 9, 18, 27 _____

11. 4, 18, 24 _____

Homework Practice**5NS2.3***Simplifying Fractions*

Replace each \square with a number so the fractions are equivalent.

1. $\frac{6}{16} = \frac{3}{\square}$

2. $\frac{5}{15} = \frac{1}{\square}$

3. $\frac{10}{35} = \frac{\square}{7}$

4. $\frac{20}{25} = \frac{4}{\square}$

Write each fraction in simplest form. If the fraction is already in simplest form, write *simplest form*.

5. $\frac{2}{4}$ _____

6. $\frac{1}{3}$ _____

7. $\frac{12}{16}$ _____

8. $\frac{9}{10}$ _____

9. $\frac{4}{15}$ _____

10. $\frac{2}{10}$ _____

Spiral Review

Solve these using the *make an organized list strategy*. (Lesson 4-2)

11. How many different arrangements are possible for the prime factors of 12? _____
12. Mr. and Mrs. Garcia have three children: Maria, Paul, and Jon. They would like to have a family picture taken. If Mr. and Mrs. Garcia stand in the back, how many different ways can their children stand in front of them? _____
13. Eric needs to go to the shoe store, the grocery store, and the library. How many different ways can Eric make the stops? _____

Problem-Solving Practice**5NS2.3***Simplifying Fractions***Solve.**

1. Alex walked 4 of the 6 blocks to school. Write this fraction in its simplest form.

2. Jennifer played 3 of 9 innings in the ball game. Write this fraction in its simplest form.

3. Mali is babysitting her neighbor's children for an hour a day. She earned \$100 in 4 weeks. Use a simplified fraction to show how much she earned in one week.

4. Casey fed 9 of the 24 animals at a veterinarian's office. His brother Tim fed 6 of 16 animals at the animal shelter. Did the brothers feed an equivalent fraction of animals? Explain your answer.

5. Shelly washed 8 of 16 cars at the school car wash. Olivia washed 1 of the 2 cars her family owns. Both girls washed $\frac{1}{2}$ of the cars being washed. Did they do the same amount of work? Explain your answer.

6. Sophia is going to plant part of a vegetable garden that was divided into 5 parts. She said that the fraction that shows the part she will plant cannot be simplified. How does she know that it cannot be simplified when she does not yet know how many parts she will plant?

Homework Practice**5NS1.5***Mixed Numbers and Improper Fractions***Write each mixed number as an improper fraction.**

1. $5\frac{2}{3}$ _____

2. $6\frac{1}{4}$ _____

3. $9\frac{1}{3}$ _____

4. $5\frac{4}{5}$ _____

5. $3\frac{3}{4}$ _____

Write each improper fraction as a mixed number or a whole number.

6. $\frac{16}{8}$ _____

7. $\frac{20}{5}$ _____

8. $\frac{5}{5}$ _____

9. $\frac{19}{6}$ _____

10. $\frac{27}{4}$ _____

Spiral Review**Replace each \square with a number so the fractions are equivalent. (Lesson 4-3)**

11. $\frac{4}{12} = \frac{1}{\square}$

12. $\frac{9}{36} = \frac{3}{\square}$

13. $\frac{8}{36} = \frac{\square}{9}$

14. $\frac{7}{14} = \frac{1}{\square}$

Write each fraction in simplest form. If the fraction is already in simplest form, write *simplest form*.

15. $\frac{8}{12}$ _____

16. $\frac{2}{7}$ _____

17. $\frac{7}{8}$ _____

18. $\frac{8}{38}$ _____

Problem-Solving Practice**5NS1.5***Mixed Numbers and Improper Fractions***Solve.**

1. During the holiday break, Anthony read one book, and half of another book. How many books did he read? Write the number as a mixed number.

2. Sam's family ate 2 pizzas. Then they ate 5 of the 8 slices of another pizza. How many pizzas did his family eat? Write the number as an improper fraction.

3. Hans ran 3 miles on the track. He took a break, then ran another $\frac{4}{5}$ mile. Write the number of miles Hans ran as an improper fraction.

4. Lindsey ran in a 10-kilometer race. This is equal to $6\frac{2}{10}$ miles. Write the number of miles Lindsey ran as a mixed number in simplest form.

5. Keisha is running on an indoor track where 8 laps equals one mile. If she runs 19 laps, how many miles is this? Write your answer as a mixed number.

6. Doug found that it takes 20 minutes to do 8 math problems. If he has to do 28 problems, how long will it take him to do them?

7. April has 4 yards of fabric. Her aunt gave her $\frac{2}{3}$ yard more fabric. How much fabric does she have in all? Write the answer as an improper fraction.

8. Austin bought 20 apples. How many dozen apples did he buy? Write the answer as a mixed number.

Homework Practice**5SDAP1.3***Least Common Multiple***Identify the first three common multiples of each set of numbers.**

1. 3, 15 _____

2. 2, 8, 12 _____

3. 6, 9, 10 _____

4. 3, 6, 18 _____

Find the LCM of each set of numbers.

5. 2, 5 _____

6. 6, 15 _____

7. 4, 16, 32 _____

8. 2, 16, 20 _____

Solve.

9. Find the two missing common multiples from the list of common multiples for 4 and 12.

48, 60, _____, 84, _____, 108, 120

10. For the drama club picture, the students must line up in rows with the same number of students. Describe the arrangements for the least number of people needed to be able to line up in rows of 5 or 6.

Spiral Review**Write each mixed number as an improper fraction. (Lesson 4-4)**

11. $7\frac{1}{3}$ _____

12. $9\frac{3}{5}$ _____

Write each improper fraction as a mixed number or a whole number.

13. $\frac{21}{8}$ _____

14. $\frac{30}{5}$ _____

Problem-Solving Practice**5SDAP1.3***Least Common Multiple***Solve**

1. List the first 10 multiples of 3 and 5 greater than zero.

What are the common multiples?

3. Noel started going to yoga class on November 3, and went every third day after that. Lana also started classes on November 3, and went every fourth day after that. In how many days will they be in class together?

5. Since Carl has moved away for college, he calls his best friend every fifth day, his parents every third day, and his grandmother every fourth day. Carl made all three calls on October 8. In how many days will he make three calls again?

What will be the date?

2. List the first 10 common multiples of 2 and 4 greater than zero.

4. Bonnie is baking a pie and a batch of cookies. She needs $\frac{3}{4}$ cup of flour for the cookies and $\frac{5}{6}$ cup of flour for the pie. Write the LCM of the denominators.

6. Lora's gymnastics class practices floor exercises every other day. The class practices on the balance beam every third day, and the uneven bars every fourth day. Today is March 10, and the class practiced all three events. How many more times, before June 1, will the class practice all three on the same day?

Homework Practice**5MR2.6, 5SDAP1.2***Problem-Solving Investigation***Use any strategy shown below to solve.**

- Guess and check. • Make an organized list.
- Make a table.

- 1.** You know that Janet spent a total of \$60 for summer clothes. At least 2 of the pairs of shorts she bought cost \$10 each. Some of her T-shirts were purchased for \$5 each. She also bought some sandals for \$10. You need to find how many of each clothing item Janet purchased.
-

- 2.** Marge went on a trip to New York City and spent a total of \$200 going to the theatre. She purchased 4 student tickets for Broadway plays that cost \$25 each and five discount tickets. Find how much each discount ticket cost.
-

- 3.** A radio station is giving every 3rd caller a T-shirt and every 10th caller a ceramic mug. Which caller will be the first to receive both prizes?
-

Spiral Review**Identify the first three common multiples of each set of numbers. (Lesson 4-5)**

4. 2, 5 _____

5. 6, 9, 18 _____

6. 3, 6, 10 _____

7. 5, 7, 15 _____

Find the LCM of each set of numbers.

8. 8, 16 _____

9. 7, 10 _____

10. 6, 12, 24 _____

Homework Practice**5SDAP1.3***Comparing Fractions*

Replace each _____ with $<$, $>$, or $=$ to make each statement true.

1. $\frac{1}{2}$ _____ $\frac{3}{5}$

2. $\frac{3}{4}$ _____ $\frac{7}{8}$

3. $\frac{7}{8}$ _____ $\frac{7}{9}$

4. $5\frac{1}{3}$ _____ $5\frac{7}{8}$

5. $8\frac{1}{8}$ _____ $8\frac{2}{3}$

Solve.

6. Order the fractions from least to greatest.

$$\frac{1}{5}, \frac{5}{8}, \frac{1}{4}, \frac{1}{2}$$

7. Andrea is using three frames, each with a different width to frame her photographs. The sizes are $8\frac{1}{2}$, $8\frac{1}{3}$, $8\frac{5}{6}$. She has decided to put the smallest in the center when she hangs them beside each other on the wall. What size frame will be in the center?

Spiral Review

Use any strategy shown below to solve. (Lesson 4-6)

- Make a table.
- Make an organized list.
- Guess and check.

8. For a yearbook picture, the 20 baseball team members must line up with an equal number of people in each row. Describe the possible arrangements in which the players could be lined up.

9. Mark needs to mow the grass, trim the hedges, and sweep the front steps before his mother gets home from work. How many different ways can Mark order these activities?

Problem-Solving Practice**5SDAP1.3***Comparing Fractions***Solve.**

- During gym class, Alicia ran $\frac{1}{2}$ mile and Nguyen ran $\frac{2}{3}$ mile. Who ran farther?

- Juanita practiced piano for $\frac{1}{2}$ hour. Her brother, Miguel, then practiced for $\frac{5}{6}$ hour. Who practiced less?

- Lucy and Randall were supposed to spend 1 hour after school practicing their soccer skills. Lucy practiced for $\frac{7}{8}$ hour and Randall practiced for $\frac{4}{5}$ hour. Who practiced closer to a full hour?

- Sasha, Tony, and Michael are reading the same book. Sasha has read $\frac{3}{4}$ of the book, Tony has read $\frac{3}{5}$, and Michael has read $\frac{2}{3}$. Who has read the most?

Who has read the least?

- At Morris Elementary there are 45 students in each grade, four through six. In the fourth grade, 19 participate in sports after school. Two out of every six fifth graders play sports after school. In the sixth-grade class, seven of every ten students are *not* playing sports. Which grade has the most students playing sports after school?

- In the fourth-grade class at Baker Elementary, 9 students are left-handed. The fifth grade has 7 left-handed students and the sixth grade has 6. The number of students in the fourth grade is 3 times the number of left-handed students in the class. The sixth grade has 3 more students than the fourth grade, and the fifth grade has two fewer students than the sixth grade. Which grade has the greatest fraction of left-handed students?

Homework Practice**5NS1.2***Writing Decimals as Fractions***Write each decimal as a fraction in simplest form.**

1. 0.2 _____

2. 6.12 _____

3. 0.375 _____

4. 0.32 _____

5. 0.125 _____

6. The newspaper reported that it rained 2.20 inches last month. Express this amount as a mixed number in simplest form.
- _____

Write each decimal as a mixed number in simplest form.

7. 6.3 _____

8. 32.50 _____

9. 40.330 _____

10. 24.500 _____

Spiral Review**Replace each _____ with $<$, $>$, or $=$ to make each statement true. (Lesson 4-7)**

11. $\frac{4}{9}$ _____ $\frac{1}{2}$

12. $\frac{3}{4}$ _____ $\frac{7}{9}$

13. $6\frac{1}{3}$ _____ $6\frac{4}{9}$

14. $9\frac{9}{8}$ _____ $9\frac{1}{4}$

Problem-Solving Practice**5NS1.2***Writing Decimals as Fractions***Solve.**

- One cup is equal to 0.5 pint. Write this decimal as a fraction in simplest form.

- Aimee needs 0.25 cup of vegetable oil to make muffins. Write this decimal as a fraction in simplest form.

- Trudy is making a picture frame and needs nails that measure 0.375 of an inch. At the hardware store, nails are measured in fractions of an inch: $\frac{1}{8}$ inch, $\frac{1}{4}$ inch, and $\frac{3}{8}$ inch. Which of these nails should she buy?

- At Richardson Elementary, 0.35 of the buses were late because of a snowstorm. Write the decimal as a fraction in simplest form.

- Neil needs about 0.33 cup of sugar for his recipe. Which of these fractions is closest to the correct measure, $\frac{1}{3}$, $\frac{1}{4}$ or $\frac{2}{3}$?

- A vitamin contains sixty-two thousandths gram of vitamin E and thirty-three thousandths gram of vitamin A. Does the vitamin contain at least twice the amount of vitamin E than vitamin A?

- Three flowers have stem widths of $\frac{1}{2}$ inch, $\frac{5}{8}$ inch, and $\frac{1}{3}$ inch. What is the measure of the flower with the greatest stem width? Write the answer as a decimal.

Homework Practice**5NS1.2***Writing Fractions as Decimals*

Write each fraction or mixed number as a decimal. Round to the nearest hundredth.

1. $\frac{7}{8}$ _____

2. $\frac{3}{40}$ _____

3. $\frac{15}{200}$ _____

4. $\frac{63}{260}$ _____

5. $3\frac{24}{80}$ _____

6. $2\frac{52}{60}$ _____

7. $3\frac{1}{3}$ _____

8. $9\frac{9}{20}$ _____

9. $12\frac{1}{16}$ _____

10. $\frac{525}{600}$ _____

11. A snake kept in a tank can grow up to $25\frac{9}{10}$ feet long. Express this length as a decimal.
-

Spiral Review

Write each decimal as a fraction in simplest form. (Lesson 4-8)

12. 0.28 _____

13. 0.3 _____

14. 0.875 _____

15. 0.020 _____

Write each decimal as a mixed number in simplest form.

16. 4.5 _____

17. 9.35 _____

18. 27.03 _____

19. 71.006 _____

Problem-Solving Practice**5NS1.2***Writing Fractions as Decimals***Solve.**

1. One cup is equal to $\frac{1}{2}$ pint. Write this fraction as a decimal in simplest form.

2. Carla needs $\frac{3}{4}$ cup of canola oil to make tortillas. Write this fraction as a decimal.

3. Hugo is making a picture frame and needs screws that measure $\frac{1}{4}$ of an inch. At the hardware store, screws are measured as 0.25, 0.75, and 0.33 inch. Which of these screws should he buy?

4. At Cromwell Elementary, 8 out of 9 of the buses were late because of a snowstorm. Write the number of late buses as a fraction and as a decimal.

5. Ned needs several pieces of wood measuring 0.33 feet. The lumber store will cut pieces only in increments of $\frac{1}{4}$ feet: $\frac{1}{3}$ feet, $\frac{1}{2}$ feet, $\frac{3}{4}$ feet, and so on. Ned agrees to have the lumber store cut the pieces, but he will have to trim some off once he gets home. He wants to trim the least amount off each piece. Which measurement should the lumber store use to cut the pieces?

6. Out of 1,000 grains of sand on a beach, Kathy estimates that 40 grains are black and 760 grains are beige. Write the fraction of beige grains of sand as a decimal.

Homework Practice**5SDAP1.5***Algebra: Ordered Pairs and Functions*

Use the coordinate plane at the right to name the ordered pair for each point.

1. P _____

2. B _____

3. S _____

4. T _____

5. J _____

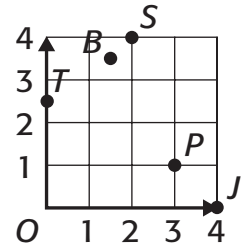

Graph and label each point on a coordinate plane.

6. M (5, 2)

7. N $(2\frac{1}{2}, 4)$

8. P (5, 2.5)

9. Q $(3\frac{3}{4}, 2)$

10. T $(0, 4\frac{1}{4})$

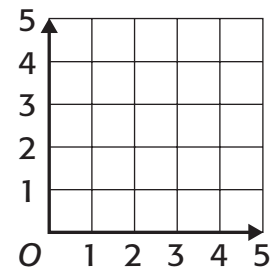
**Spiral Review**

Write each fraction or mixed number as a decimal. Round to the nearest hundredth. (Lesson 4-9)

11. $\frac{65}{90}$ _____

12. $\frac{81}{200}$ _____

13. $5\frac{6}{564}$ _____

14. $6\frac{3}{960}$ _____

15. $3\frac{49}{60}$ _____

16. $18\frac{72}{680}$ _____

17. $7\frac{2}{3}$ _____

18. $3\frac{59}{80}$ _____

19. $\frac{410}{500}$ _____

20. $\frac{35}{300}$ _____

Problem-Solving Practice**5SDAP1.5***Algebra: Ordered Pairs and Functions***Solve.**

- Mishka identified a point that was 5 units above the origin and 4 units to the right on a graph. What was the ordered pair?

- Geraldo plotted $(7, 9)$ on a graph. How many units above the origin is the point located?
_____ units
- Amanda used the following ordered pairs to graph the function $t = 5s + 2$. Which of the following is not an ordered pair of the form (s, t) for this function: $(0, 2)$, $(4, 22)$, $(7, 1)$, or $(2, 12)$? Explain your answer.

- Lindy collected temperature over time data in science class. She wrote the following ordered pairs for (x, y) : $(0, 3)$, $(2, 7)$ and $(5, 13)$. Using a separate sheet of graph paper, graph the points, and connect the points with a line.
From the graph, predict the value for y if $x = 4$.
 $y =$ _____
- Louis worked in an electronics store. Every day, he earned a flat rate of \$20 plus \$6 per hour. Write a function that shows how much he earned in a day, depending on how long he worked.

What ordered pair in the form of (h, d) shows how much he earned if he worked 4 hours?

What if he worked 6 hours?

- Ruth rode her bicycle at a steady rate of 6 miles per hour. As she went down a long hill, her speed increased 1 mile per hour every 10 seconds. Write the equation for this function if s is her speed and t is units of 10 seconds.

Write the ordered pairs for $t = 30$ seconds and $t = 40$ seconds.

Homework Practice**5MR2.5, 5NS1.1***Rounding Fractions and Mixed Numbers***Round each number to the nearest half.**

1. $2\frac{1}{12}$ _____

2. $4\frac{5}{11}$ _____

3. $7\frac{3}{10}$ _____

4. $\frac{8}{12}$ _____

5. $6\frac{2}{9}$ _____

6. $\frac{14}{16}$ _____

7. $8\frac{6}{16}$ _____

8. $10\frac{7}{12}$ _____

9. $\frac{3}{8}$ _____

Solve.

10. Your basement has an $8\frac{3}{12}$ foot ceiling. To the nearest half foot, how tall is the tallest cabinet that can fit in the basement?
- _____

11. Alice is giving a book as a gift that is $8\frac{3}{8}$ inches long and $6\frac{1}{12}$ inches wide. Will the book fit in a box that is $8\frac{1}{2}$ inches long and $6\frac{1}{2}$ inches wide or in a box that is 8 inches long and 6 inches wide?
- _____

Spiral Review**Graph each ordered pair on the coordinate plane at the right.**

12. $M(4, 3)$

13. $N(1\frac{1}{2}, 2)$

14. $P(3, 2.5)$

15. $Q(4\frac{3}{4}, 5)$

16. $T(2, 2\frac{1}{4})$

17. $V(1, 3\frac{1}{2})$

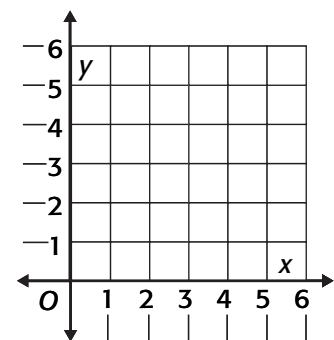

Problem-Solving Practice**5MR2.5, 5NS1.1***Rounding Fractions and Mixed Numbers***Solve.**

1. A recipe for cookies calls for $\frac{3}{4}$ of a cup of chocolate chips. Should you buy a package with 1 cup or a package with $\frac{6}{8}$ of a cup?

2. The cookie recipe also calls for $\frac{3}{8}$ of a cup of walnuts. Should you buy a package with 1 cup or a package with $\frac{1}{2}$ cup of walnuts?

3. Your kitchen has a $9\frac{3}{4}$ foot ceiling. To the nearest half foot, what is the tallest refrigerator that can fit in the kitchen under a cabinet that hangs down 3 feet?

4. Russ is putting his photographs in an album that is $12\frac{1}{8}$ inches long and $10\frac{1}{2}$ inches wide. Should he trim the edges of the photographs to 12 inches long and 10 inches wide or to $12\frac{1}{4}$ inches long and $10\frac{1}{4}$ inches wide?

5. A farmer is planting squash plants that need $2\frac{3}{8}$ feet to spread out. He has an area along a fence that is 20 feet long. Round the amount of space the squash plants need to the nearest $\frac{1}{2}$ foot. How many squash plants can the farmer grow along the fence?

6. Based on the area of his flowerbed, a gardener calculates that he needs to dilute $6\frac{8}{14}$ gallons of fertilizer with water. Should he round $6\frac{8}{14}$ up or down when deciding on the amount of fertilizer he should purchase?

Homework Practice**5MR2.5, 5NS1.1***Estimating Sums and Differences***Estimate the sum or difference.**

1. $4\frac{1}{3} + \frac{8}{9}$ _____

2. $7\frac{1}{6} + \frac{7}{15}$ _____

3. $\frac{9}{10} + 3\frac{2}{3}$ _____

4. $8\frac{7}{8} - 1\frac{6}{9}$ _____

5. $1\frac{2}{10} + 3\frac{1}{9}$ _____

6. $7\frac{1}{3} + 7\frac{1}{8}$ _____

7. $3\frac{5}{8} + 6\frac{3}{5}$ _____

8. $\frac{7}{15} + 2\frac{5}{9}$ _____

9. $6\frac{7}{8} - \frac{4}{7}$ _____

10. $10\frac{7}{8} - \frac{5}{9}$ _____

Spiral Review**Round to the nearest half. (Lesson 5-1)**

11. $5\frac{2}{3}$ _____

12. $8\frac{2}{13}$ _____

13. $9\frac{10}{10}$ _____

14. $\frac{6}{12}$ _____

15. $4\frac{1}{9}$ _____

16. $\frac{14}{18}$ _____

17. $7\frac{9}{15}$ _____

18. $11\frac{7}{24}$ _____

19. $\frac{5}{6}$ _____

20. $18\frac{1}{12}$ _____

Problem-Solving Practice**5MR2.5, 5NS1.1***Estimating Sums and Differences***Solve.**

- Abdul works $\frac{3}{4}$ hour one day and $\frac{1}{3}$ hour the next day. Estimate the total number of hours he works on both days combined.

about _____ hours
- Anna is making cookies for the school bake sale. If she uses $1\frac{1}{8}$ pounds of flour per batch, what is the amount of flour she needs for four batches?

_____ pounds
- Rachel sings in a chorus at a concert. The songs are $4\frac{3}{10}$ minutes, $7\frac{1}{12}$ minutes, and $10\frac{3}{4}$ minutes long. Estimate the amount of time the chorus spends singing.

about _____ minutes
- Kathy rides her bicycle to her aunt's house. It takes her $20\frac{2}{3}$ minutes to get there. She is tired when she leaves, and it takes her $24\frac{1}{6}$ minutes to ride home. What is the approximate difference in the two times?

_____ minutes
- Carol wants to make a picture frame for an 8×10 inch photo. The long pieces of the frame need to be $12\frac{1}{8}$ inches long. The short pieces should be $10\frac{1}{4}$ inches long. Estimate the length of wood Carol must buy to make the frame.

about _____ inches

Would this length be the actual amount she should buy? Explain.

- Justin plays football. On one play, he ran the ball $24\frac{1}{3}$ yards. The following play, he was tackled and lost $3\frac{2}{3}$ yards. The next play, he ran for $5\frac{1}{4}$ yards. Estimate how much farther the ball is down the field after the three plays.

about _____ yards

Homework Practice**5NS2.3***Adding and Subtracting Fractions with Like Denominators***Add or subtract. Write in simplest form.**

1. $\frac{2}{5} + \frac{8}{5} =$ _____

2. $\frac{5}{9} - \frac{1}{9} =$ _____

3. $\frac{6}{8} - \frac{5}{8} =$ _____

4. $\frac{3}{4} + \frac{2}{4} =$ _____

5. $\frac{9}{9} + \frac{3}{9} =$ _____

6. $\frac{7}{8} + \frac{2}{8} =$ _____

7. $\frac{1}{2} + \frac{2}{2} =$ _____

8. $\frac{4}{5} - \frac{3}{5} =$ _____

9. $\frac{12}{15} + \frac{3}{15} =$ _____

10. $\frac{6}{7} - \frac{1}{7} =$ _____

Spiral Review**Estimate. (Lesson 5-2)**

11. $2\frac{1}{2} + \frac{5}{9} =$ _____

12. $5\frac{4}{6} + \frac{1}{2} =$ _____

13. $\frac{2}{3} + 6\frac{1}{5} =$ _____

14. $3\frac{7}{8} - 1\frac{2}{9} =$ _____

15. $8\frac{2}{10} + 3\frac{1}{9} =$ _____

16. $1\frac{1}{3} + 7\frac{6}{7} =$ _____

17. $8\frac{5}{8} + 6\frac{3}{5} =$ _____

18. $\frac{5}{15} + 7\frac{5}{9} =$ _____

19. $\frac{7}{8} - \frac{1}{7} =$ _____

20. $1\frac{1}{8} - \frac{5}{9} =$ _____

21. $\frac{5}{8} + \frac{11}{2} =$ _____

22. $3\frac{6}{7} - 1\frac{2}{3} =$ _____

Problem-Solving Practice**5NS2.3***Adding and Subtracting Fractions with Like Denominators***Solve. Write your answer in simplest form.**

- Debbie helped her mother with the laundry. She did $\frac{1}{8}$ of it on Monday and another $\frac{3}{8}$ of it on Tuesday. What fraction of the laundry has she done?

- Laureano worked $\frac{1}{4}$ hour one day and $\frac{3}{4}$ hour the next day. How many hours did he work on the two days?

- Mindy likes to order fresh meat and vegetable wraps from a local restaurant. One cook can roll $\frac{1}{3}$ wraps in 5 minutes. Another cook can roll $\frac{2}{3}$ wraps in the same amount of time. What is the difference in the number of wraps the two cooks can prepare in 5 minutes?

- John went to a museum to see model trains. He saw $\frac{2}{5}$ mile of track on the first floor of the museum. He saw $\frac{4}{5}$ mile of track on the second floor. How much more track did John see on the second floor than the first?

- Laura and her sister Katie swim every day. Laura can swim $\frac{3}{7}$ mile in 10 minutes. Katie can swim $\frac{2}{7}$ mile in the same amount of time. If they swim for 20 minutes and their speeds stay the same, how much farther does Laura swim than her sister?

Homework Practice**5MR2.3, 5NS2.3***Problem-Solving Strategy***Solve. Use the *act it out* strategy.**

1. Alberto has 12 quarters, 10 dimes, 10 nickels, and 20 pennies. How many different combinations of coins can he make to have \$2?

2. Carlos is running drills of $\frac{1}{2}$ mile. If he runs 5 drills, how many miles did he run?

3. Students are hanging their art projects in the school hallway. Each student wants to hang a project that is $\frac{7}{8}$ foot wide. The hallway is 16 feet long. If they don't leave any space between each project, how many projects will fit in the hallway?

4. Hana is wrapping books to give as gifts. She needs pieces of wrapping paper that are $\frac{5}{6}$ feet long for each book. She has a total of 6 books. How long a roll of wrapping paper will she need?

Spiral Review**Add or subtract. Write in simplest form. (Lesson 5-3)**

5. $\frac{3}{5} + \frac{9}{5}$

6. $\frac{3}{9} - \frac{1}{9}$

7. $\frac{7}{8} - \frac{2}{8}$

8. $\frac{3}{4} + \frac{1}{4}$

9. $\frac{9}{9} - \frac{3}{9}$

10. $\frac{5}{8} + \frac{6}{8}$

11. $\frac{1}{2} + \frac{2}{2}$

12. $\frac{6}{5} - \frac{2}{5}$

13. $\frac{12}{15} - \frac{3}{15}$

14. $\frac{6}{8} - \frac{2}{8}$

15. $\frac{5}{8} + \frac{3}{8}$

16. $\frac{5}{8} - \frac{3}{8}$

Homework Practice*Adding and Subtracting Fractions
with Unlike Denominators***Add or subtract. Write in simplest form.**

1. $\frac{2}{5} + \frac{2}{8}$ _____

2. $\frac{3}{6} + \frac{7}{8}$ _____

3. $\frac{9}{10} - \frac{2}{8}$ _____

4. $\frac{5}{7} + \frac{1}{2}$ _____

5. $\frac{3}{4} - \frac{5}{8}$ _____

6. $\frac{1}{6} + \frac{1}{4}$ _____

7. $\frac{2}{5} + \frac{3}{6}$ _____

8. $\frac{3}{4} - \frac{1}{2}$ _____

9. $\frac{2}{3} - \frac{1}{10}$ _____

10. $\frac{2}{7} + \frac{1}{3}$ _____

11. $\frac{3}{8} + \frac{7}{9}$ _____

12. $\frac{8}{9} + \frac{1}{10}$ _____

13. $\frac{1}{2} + \frac{2}{3}$ _____

14. $\frac{3}{5} - \frac{1}{8}$ _____

15. $\frac{9}{10} - \frac{1}{6}$ _____

16. $\frac{6}{7} + \frac{1}{2}$ _____

Spiral Review**Solve using the *act it out* strategy. (Lesson 5-4)**

17. The Boyd family eats $\frac{3}{4}$ of a package of pasta for dinner. How many packages of pasta will they need for 4 pasta dinners?

18. Kayla has 5 quarters, 3 dimes, 2 nickels, and 5 pennies. How many different combinations of coins can she make to have \$0.50?

Problem-Solving Practice**5NS2.3***Adding and Subtracting Fractions
with Unlike Denominators***Solve. Write in simplest form.**

- Steve watched television for $\frac{3}{4}$ hour on Monday and $\frac{5}{6}$ hour on Tuesday. How many hours did he watch television on both days?

- Deanna uses $\frac{2}{3}$ cup of flour and $\frac{1}{4}$ cup of shortening in a pie crust recipe. How much more flour than shortening does she use?

- Marsha and her friend, Tina, are making table decorations for a party. Marsha made $\frac{2}{9}$ of a decoration in half an hour. Tina can make $\frac{2}{3}$ of a decoration in the same amount of time. How much more of a decoration can Tina make in half an hour?

- Kyle planted flowers in the front of the school. He planted $\frac{11}{16}$ of the plants on Friday and $\frac{1}{4}$ of the plants on Saturday. What fraction of the total plants did he plant on both days?

- After school, Laura babysits a neighbor's child for 50 minutes. They rest for 10 minutes, read for 15 minutes, and play for the rest of the time. Write the total babysitting time, the resting time, and the reading time, as fractions of an hour.

Use these fractions to find the fraction of an hour they play.

- Shawn rides his bicycle $\frac{9}{10}$ mile to school. On his way to school, he stops at Mike's house, which is $\frac{1}{5}$ mile from Shawn's house. Then they both ride to Jose's house, which is $\frac{2}{7}$ mile from Mike's house. How far is it from Jose's house to the school?

Homework Practice**5MR2.3, 5NS2.3***Problem-Solving Investigation***Use any strategy shown below to solve.**

- Make a table
- Use logical reasoning
- Act it out

1. Olivia bought a ring for $\frac{1}{2}$ off the regular price. If she paid \$50, what was the regular price?
-

2. Mrs. Jones told the class that $\frac{1}{3}$ of them scored 90 or above on the math test. Another $\frac{1}{3}$ of them had a passing score. What fraction of the class failed?
-

3. At a park, a picnic shelter covers $\frac{1}{4}$ of an acre and a playground covers $\frac{5}{8}$ of an acre. How much area is covered by both the picnic shelter and the playground?
-

4. Of the 300 students at school, 110 are in the chorus and 150 are in the band. Of these students, 50 are in both chorus and the band. How many students are neither in the chorus nor the band?
-

Spiral Review**Add or subtract. Write in simplest form. (Lesson 5-5)**

5. $\frac{3}{5} + \frac{2}{9}$ _____

6. $\frac{3}{5} + \frac{6}{8}$ _____

7. $\frac{7}{10} + \frac{2}{7}$ _____

8. $\frac{6}{7} + \frac{1}{2}$ _____

9. $\frac{7}{8} - \frac{3}{5}$ _____

10. $\frac{5}{6} + \frac{1}{3}$ _____

Homework Practice**5NS2.3***Adding and Subtracting Mixed Numbers***Add or subtract. Write in simplest form.**

1. $3\frac{3}{4} + 8\frac{1}{4}$ _____

2. $6\frac{1}{5} + 6\frac{3}{5}$ _____

3. $11\frac{3}{10} + 1\frac{1}{10}$ _____

4. $6\frac{5}{8} + 7\frac{6}{8}$ _____

5. $9\frac{4}{8} - 6\frac{1}{8}$ _____

6. $8\frac{1}{3} + 9\frac{2}{3}$ _____

7. $5\frac{1}{5} + 7\frac{3}{5}$ _____

8. $9\frac{1}{9} - 1\frac{8}{9}$ _____

9. $7\frac{6}{7} - 5\frac{1}{7}$ _____

10. $12\frac{4}{8} - 4\frac{1}{8}$ _____

Spiral Review**Use any strategy shown below to solve. (Lesson 5-6)**

- Make a table
- Use logical reasoning
- Act it out

- 11.** Janice bought 2 pairs of sneakers. The first pair was full price and the second was half price. The original price of the first pair was \$32. How much did she spend?

- 12.** Jill bought five packages of printer paper that weighed $1\frac{1}{2}$ pounds, $2\frac{1}{8}$ pounds, $3\frac{3}{4}$ pounds, $1\frac{1}{8}$ pounds, and $2\frac{1}{2}$ pounds. How many pounds of paper did she buy?

- 13.** Chou's quiz scores are 78, 99, 101, 88, 93, 89, 92, 94, 84, 95. On how many more quizzes did Chou score above 90 than below 90?

Problem-Solving Practice**5NS2.3***Adding and Subtracting Mixed Numbers***Solve.**

- Blanca's children are $6\frac{1}{6}$ years old and $5\frac{1}{12}$ years old. In simplest form, what are combined ages of her children?

- Rick has a choice of buying $4\frac{1}{4}$ packages of pencils or $2\frac{2}{5}$ packages of pens. In simplest form, how many more packages of pencils than pens can he buy?

- Cumberland Valley Coal Company mined $249\frac{2}{3}$ tons of coal on one day and $387\frac{1}{7}$ tons on another day. What is the total number of tons of coal mined on both days?

- One year, Cumberland Valley Coal Company planted $14\frac{1}{6}$ dozen trees to help prevent erosion. The following year, they planted $20\frac{2}{3}$ dozen trees. How many more trees did they plant the second year?

- James learned in science class that the amount of energy it takes to produce $1\frac{1}{8}$ pounds of aluminum from ore can be used to create $22\frac{1}{2}$ pounds of recycled aluminum. If $2\frac{1}{4}$ pounds of aluminum is produced from ore, how many pounds of recycled aluminum could be created using the same amount of energy?

- Bethany bought $2\frac{1}{2}$ pounds of bread, $3\frac{1}{4}$ pounds of meat, and $3\frac{1}{3}$ pounds of cheese to make sandwiches for a party. She also bought $2\frac{1}{3}$ pounds of tomatoes, $1\frac{1}{6}$ pounds of onions, and $2\frac{1}{2}$ pounds of lettuce.

What is the total number of pounds of food that she bought?

How much more recycled aluminum than aluminum can be produced for this amount of energy?

Homework Practice**5NS2.3***Subtracting Mixed Numbers with Renaming***Subtract. Write in simplest form.**

1. $7 - 4\frac{1}{2}$ _____

2. $9 - 5\frac{3}{5}$ _____

3. $6 - 2\frac{2}{3}$ _____

4. $14 - 5\frac{1}{4}$ _____

5. $10\frac{5}{8} - \frac{2}{8}$ _____

6. $12\frac{2}{10} - 6\frac{1}{10}$ _____

7. $5\frac{1}{2} - 4$ _____

8. $3\frac{1}{3} - 1\frac{1}{3}$ _____

9. $8\frac{6}{7} - 2$ _____

10. $3\frac{2}{8} - 1\frac{1}{8}$ _____

11. $9\frac{2}{3} - 3\frac{5}{6}$ _____

12. $2\frac{1}{10} - 1\frac{2}{5}$ _____

13. $15\frac{7}{12} - 8\frac{1}{2}$ _____

14. $6\frac{7}{16} - 2\frac{7}{8}$ _____

Spiral Review**Add or subtract. Write in simplest form. (Lesson 5-7)**

15. $2\frac{2}{4} + 7\frac{1}{4}$ _____

16. $5\frac{1}{5} + 2\frac{3}{5}$ _____

17. $1\frac{3}{10} + 11\frac{8}{10}$ _____

18. $6\frac{5}{8} - 4\frac{6}{8}$ _____

19. $9\frac{4}{8} + 6\frac{1}{8}$ _____

20. $7\frac{1}{3} - 5\frac{2}{3}$ _____

21. $5\frac{2}{5} + 4\frac{3}{5}$ _____

22. $9\frac{1}{9} - 3\frac{5}{9}$ _____

23. $7\frac{6}{7} + 5\frac{1}{7}$ _____

24. $11\frac{3}{8} - 4\frac{5}{8}$ _____

Problem-Solving Practice**5NS2.3***Subtracting Mixed Numbers with Renaming***Solve.**

1. When Shane and her family went on vacation, the pilot announced that it would take $4\frac{1}{4}$ hours to reach their destination. When the flight snack was served, they had been in flight $2\frac{3}{4}$ hours. How much longer was the flight after the snack was served?
-

2. Mark bought $5\frac{1}{4}$ pounds of yellow cheese and $3\frac{3}{5}$ of white cheese. How much more yellow cheese than white cheese did he buy?
-

3. Stella made 4 quarts of lemon tea for the weekend barbecue. Vincent made $3\frac{1}{6}$ quarts of mint tea for the barbecue. How much more tea did Stella make than Vincent?
-

4. Taylor's puppy weighs 9 pounds. Belinda's kitten weighs $3\frac{3}{5}$ pounds. How much more does Taylor's puppy weigh than Belinda's kitten?
-

5. Jillian has a piece of leather cord that is $12\frac{1}{5}$ inches long. She only needs $8\frac{9}{10}$ inches of yarn to make a bracelet. How much leather cord will she trim?
-

6. The Department of Education prohibits a student from doing more than 50 hours of homework in a 7-day period. Silvio has done homework for $30\frac{1}{4}$ hours in the last 5 days. How many more hours is he allowed to do homework in the next 2 days?
-

Homework Practice**5NS2.1***Multiplying Decimals by Whole Numbers***Multiply.**

1. 4.7×4 _____

2. 2.9×7 _____

3. 8×0.5 _____

4. 6×0.02 _____

5. 0.09×6 _____

6. 0.011×5 _____

Write each number in standard form.

7. 6×10^4 _____

8. 5×10^2 _____

9. 1.45×10^3 _____

10. 8.2×10^5 _____

11. 0.067×10^8 _____

12. 2.6×10^1 _____

Spiral Review**Solve.**

13. $4 \times 7 - 8$ _____

14. $10 \times 6 + 24$ _____

Add or subtract.

15. $\frac{3}{5} + 3\frac{3}{8}$ _____

16. $9 + 4\frac{1}{2}$ _____

17. $16 - 5\frac{3}{5}$ _____

Problem-Solving Practice**5NS2.1***Multiplying Decimals by Whole Numbers***Solve.**

- Andrea earns \$32.00 a day. What will she earn if she works 10 days?

- Constantino cooked 5.2 lbs of beef. Each pound is 16 oz. How many ounces of beef did he cook?

- Kasi is traveling in the United States. If the exchange rate is 58 rupees for every American dollar, how many rupees does it take to purchase a meal that costs \$12.98?

- A school receives \$14.00 for every 1,000 labels they collect from certain products. How much money will they make if students collect 3,000 labels?

- Kevin is studying Spanish, and he learns about 5.3 new words each school day. Lisa is studying French, and she learns about 4.9 new words each school day. About how many more words will Kevin learn than Lisa in 4 weeks?

- An amusement park charges \$35.50 for admission. On one day, 6,789 people visited the park. The park employed 779 people that day and paid each of them an average of \$86.00 for the day. The park also paid \$17,295.00 for electricity, maintenance of the rides, and supplies. How much money did the park make that day?

Homework Practice**5NS2.1***Multiplying Decimals***Multiply.**

1. 0.7×0.8 _____

2. 2.9×7.5 _____

3. 8.8×0.5 _____

4. 7.3×0.02 _____

5. 0.011×6.3 _____

6. 0.071×5.5 _____

Evaluate each expression if $a = 9.4$ and $b = 0.76$ and $c = 2.78$

7. $7.5a$ _____

8. $5.33b$ _____

9. $1.8c$ _____

10. $.037 + 4.45a$ _____

11. $ab + c$ _____

12. $5.84a$ _____

13. $16 - 4c$ _____

14. $10 \times 8 + ab$ _____

15. $bc + a$ _____

16. If you pay 20 cents a pound for bananas, and you buy 6 pounds of bananas, what is the total amount?
- _____

Spiral Review**Multiply. (Lesson 6-1)**

17. 7×4.5 _____

18. 4.9×5 _____

19. 7.1×2 _____

20. 9×3.2 _____

Problem-Solving Practice**5NS2.1***Multiplying Decimals***Solve.**

1. Christopher walks 1.8 hours at a rate of 3.2 mi/hr. How many miles does he walk?

2. Kristin can ride her bike 6.2 mile in an hour. How far can she ride in 2.94 hours?

3. Anna works in a bakery and makes an average of 2.7 pies an hour. Her normal workday is 7.5 hours. How many pies does she make in an average day?

4. Michael multiplies 1.7×28.2 and says that the answer is 4.794. The numbers are correct, but the decimal point is in the wrong place. Use estimation to find what the answer should actually be.

5. Jimmy works in a factory. He has to produce 23.9 car parts in an hour to make the number of parts required in a 7.5-hour workday. How many parts is he supposed to make in a day? One day he works faster than usual, producing 30.8 car parts per hour. How many parts does he make?

6. Heather can read an average of 62.7 pages in an hour. She finished her homework and has 2.87 hours to read before she has to go to sleep. Will she be able to read a 200-page book that evening? Explain your answer.

Homework Practice**5MR3.1, 5NS2.1***Problem-Solving Strategy***Check for Reasonableness****Solve.**

1. Jamil volunteers once a week. He works for 3.5 hours at a time. How many hours does he work in 10 weeks?

2. Gamal collects cards. If he buys 4 cards a week, how many total cards will he have after 3 months?

3. Kim invited 5 friends over to swim. They took turns on the 3 rafts. If they each lay on a raft for 30 minutes at a time, how long would it take for all 5 friends to have their turn?

4. Ling ordered 3 hamburgers, 2 fries, and 3 drinks. If he paid with three 10-dollar bills, how much change will he get back?

| Item | Cost |
|-----------|--------|
| Hamburger | \$3.50 |
| Fries | \$2.90 |
| Drink | \$3.95 |

Spiral Review**Multiply. (Lesson 6-2)**

5. 5×2.8 _____

6. 3.7×7 _____

7. 8×4.6 _____

8. 6.2×3.4 _____

9. 8.1×6.4 _____

10. 5.3×2.9 _____

Homework Practice**5NS2.1, 5NS2.2***Dividing Decimals by Whole Numbers***Divide. Round to the nearest tenth if necessary.**

- | | | |
|--------------------------|--------------------------|--------------------------|
| 1. $4.79 \div 3$ _____ | 2. $9.99 \div 7$ _____ | 3. $0.55 \div 5$ _____ |
| 4. $6.95 \div 6$ _____ | 5. $55.35 \div 52$ _____ | 6. $72.9 \div 4$ _____ |
| 7. $853.7 \div 25$ _____ | 8. $457.4 \div 32$ _____ | 9. $158.6 \div 45$ _____ |
| 10. $64.3 \div 6$ _____ | 11. $49.7 \div 4$ _____ | 12. $74.2 \div 2$ _____ |

Find the mean for each set of data. Round to the nearest tenth.

13. 25.8, 26.9, 24.2, 23.9, 25.4 _____ 14. 2.56, 1.72, 2.85, 3.10, 2.65 _____

Spiral Review**Solve. Is each answer reasonable? Explain. (Lesson 6-3)**

15. Laura thinks that a horse weighs 750 ounces. Is her estimate reasonable?

16. Vito's living room is 13 feet wide and 10 feet long. Will 2 yards of carpet cover the floor?

17. Esse has a recipe that calls for 2 quarts of tomato sauce. Will 8 cups be enough?

Problem-Solving Practice**5NS2.1, 5N2.2***Dividing Decimals by Whole Numbers***Solve.**

1. Pablo paid \$14.75 for 5 identical items. How much did each item cost?

2. Marianne measured the rainfall in her area for a year. Her readings totaled 34.56 in.
What is the average rainfall per month?
_____ in.
3. Silvia is learning Spanish in school. At the end of the 9-month school year, she had learned 422 new words.
To the nearest tenth, how many words did she learn each month?
_____ words
4. Lon earned \$242.88 doing yard work. He owed his brother some money and was paying him back \$25 at a time.
To the nearest whole number, how many payments could he make from the money he earned?
_____ payments

Solve. Round to the nearest tenth if necessary.

5. Harry's mother makes cakes for a local restaurant. She buys flour and sugar in large amounts. The last time she shopped, she bought 157.86 lb of flour and 82.69 lb of sugar.
If she uses 15 lb of flour and 8 lb of sugar in a day, how many days will the flour last?
_____ days

How many days will the sugar last?
_____ days
6. The Weston Laundry washes all the linens for local hotels. In 7 days, they washed 2,853.8 lb of towels and 3,534.7 lb of sheets.
How many pounds of laundry did they wash each day?
_____ pounds

Homework Practice**5NS2.1, 5NS2.2***Dividing by Decimals***Divide. Round to the nearest tenth if necessary.**

1. $7 \div 0.77$ _____

2. $9.7 \div 2.5$ _____

3. $8.8 \div 0.5$ _____

4. $9.3 \div 0.03$ _____

5. $8.3 \div 0.010$ _____

6. $5.5 \div 0.85$ _____

Evaluate each expression if $a = 0.42$, $b = 0.73$, and $c = 3.48$

7. $7.5 \div a$ _____

8. $6.77 \div c$ _____

9. $3.4 \div a$ _____

10. $\frac{0.135 + 7.45}{b}$ _____

11. $c \div b \times a$ _____

12. $b \times c \div 1.9$ _____

13. $10 \div 2 \times c$ _____

14. If you pay \$2.70 for corn, and you buy 5 pounds of corn, what is the cost per pound?

Spiral Review**Divide. Round to nearest tenth if necessary. (Lesson 6-4)**

15. $14.8 \div 6$ _____

16. $76.2 \div 4$ _____

17. $2.31 \div 8$ _____

18. $11.2 \div 16$ _____

19. $254.9 \div 7$ _____

20. $1.5 \div 3$ _____

21. If you buy dirt for your garden for \$104.40 and you buy 58 pounds of dirt, what is the cost per pound?

Problem-Solving Practice**5NS2.1, 5NS2.2***Dividing by Decimals***Divide. Round your answer to the nearest tenth if necessary.**

1. Zachary's pet snake eats 18 meals in 5.5 weeks. How many meals does the snake eat in 1 week?

2. The Garcia family drove 234.8 miles for a family reunion and used 9.4 gallons of gas. How many miles did they get per gallon?

3. Marco loves to jog. He jogs 3.2 miles every day. How many days would it take Marco to jog 96 miles?

4. A can of tomatoes weighs 16.5 ounces. A grocery store receives a box of canned tomatoes that weighs 412.5 ounces. How many cans of tomatoes are in the box?

5. At the school store, pencils are on sale for \$0.17 each. Mara spends \$1.36 on pencils. How many pencils did she buy?

6. A cheetah can sprint at a speed of 70 miles per hour. A very fast human can sprint at a speed of 14.7 miles per hour. How many times faster is the cheetah than a human?

7. Ming is making cereal bars for her school bake sale. She uses 0.3 box of cereal for each batch of bars. If Ming has 3.6 boxes, how many batches can she make?

Homework Practice**5MR1.1, 5NS2.1***Problem-Solving Investigation***Solve. Use any strategy to solve.**

1. Hoshi attends her ballet class each week. At class, the students dance for 2.3 hours at a time. How many hours does she dance at class in 20 weeks?

2. Seki had her friends over to play. They played a board game for 45 minutes and then played cards for 30 minutes. They built a fort for 45 minutes and painted for another 30 minutes. How long was the play date?

3. Jack ordered 3 drums, 2 blankets, and 3 pants. If he paid with eight 20-dollar bills, how much change will he get back?

| Item | Cost |
|---------|---------|
| Blanket | \$15.95 |
| Pants | \$12.99 |
| Drum | \$24.95 |

Spiral Review**Divide. (Lesson 6-5)**

4. $8.4 \div 0.6$ _____

5. $0.792 \div 2.1$ _____

6. $34.87 \div 3.8$ _____

7. $0.19 \div 0.07$ _____

8. If you buy rocks for your garden for \$2.80 a pound, how much will it be for 150 pounds?

9. If you buy the same rocks and need 3.8 times that many, how much will you pay?

Homework Practice**5MR2.5, 5NS2.5***Estimating Products of Fractions***Estimate each product.**

1. $36 \times \frac{1}{5}$ _____

2. $\frac{5}{8} \times 100$ _____

3. $\frac{1}{3} \times 23$ _____

4. $\frac{2}{3} \times 76$ _____

5. $\frac{5}{7} \times \frac{1}{8}$ _____

6. $5\frac{4}{5} \times 8\frac{7}{8}$ _____

Estimate the area of the rectangle.7. The length is $4\frac{6}{8}$ ft and the width is $7\frac{2}{5}$ ft.
_____8. The width is $24\frac{3}{5}$ ft and the length is $8\frac{2}{3}$ ft.
_____9. A garden measures $5\frac{1}{3}$ ft by $10\frac{2}{3}$ ft.
_____**Spiral Review****Use any strategy shown below to solve. (Lesson 6-6)**

- Make an organized list.
- Determine reasonable answers.
- Use logical reasoning.

10. If you pay 25 cents a pound for apples, and you buy 12 pounds of apples, what is the total amount?

11. You buy a shirt online that costs \$39.30. Shipping and handling was d dollars. Write an equation that represents the relationship between the delivery fee and the total cost.

Problem-Solving Practice**5MR2.5, 5NS2.5***Estimating Products of Fractions***Estimate each product.**

1. The baseball team practices $1\frac{3}{4}$ hr after school. About how many hours do they practice each week?

2. Tyra has 6 bricks. Each brick is $8\frac{1}{4}$ in. long. She lays them end-to-end to make a border in her garden. About how long is the border?

3. A living room measures $23\frac{3}{4}$ ft wide by $23\frac{1}{4}$ ft long. Estimate the area of the room. [Hint: To find the area, multiply the width times the length.]

4. Casey and his brother plan to baby-sit for $44\frac{1}{2}$ hr this month. His brother plans to do $\frac{1}{5}$ of the baby-sitting. About how much time will Casey's brother spend baby-sitting?

5. Neesa has 98 pictures from her trip to Mexico. She will take $\frac{3}{4}$ of the best shots and put them into a scrapbook. Each page can hold 4 or 5 pictures. About how many pages will she use if she puts 4 pictures on each page? If she puts 5 pictures on each page?

6. Chang has 288 baseball cards of players from his favorite teams. About one third of them are Boston players, about one sixth are Oakland players, and about one twelfth are Texas players. About how many cards do not represent players from these teams?

Homework Practice**5NS2.5***Multiplying Fractions***Multiply. Write in simplest form.**

1. $\frac{1}{2} \times \frac{1}{4}$ _____

2. $\frac{5}{6} \times \frac{2}{3}$ _____

3. $\frac{3}{4} \times 3$ _____

4. $\frac{4}{9} \times \frac{2}{8}$ _____

5. $\frac{1}{2} \times \frac{1}{3} \times \frac{1}{4}$ _____

6. $\frac{2}{3} \times \frac{7}{8} \times \frac{1}{4}$ _____

Evaluate each expression if $a = \frac{1}{2}$, $b = \frac{3}{8}$, and $c = \frac{4}{5}$.

7. $5a$ _____

8. $15c$ _____

9. $\frac{1}{3}c$ _____

10. $\frac{3}{4}a + \frac{2}{3}c$ _____

11. $ab + c$ _____

12. $\frac{4}{7}b$ _____

13. You pay $\frac{1}{6}$ the price for apples as compared to grapefruit. If the grapefruit is 2.99/lb, how much do you pay for apples per pound?

Spiral Review**Estimate each product. (Lesson 6-7)**

14. $\frac{6}{7} \times \frac{1}{4}$ _____

15. $\frac{1}{5} \times 31$ _____

16. $\frac{2}{3} \times 61$ _____

17. $11\frac{1}{4} \times 7\frac{1}{10}$ _____

18. $\frac{1}{3} \times 28$ _____

19. $2\frac{7}{9} \times 6\frac{1}{4}$ _____

Problem-Solving Practice**5NS2.5***Multiplying Fractions***Solve.**

1. Renee wants to make a $\frac{1}{4}$ batch of muffins. If the full recipe calls for $\frac{1}{2}$ cup of milk, how much milk must she use for this smaller batch?

2. Rob spends $\frac{1}{2}$ hour each day caring for his pets. He spends $\frac{1}{2}$ of the time taking care of his birds. How much time does Rob spend taking care of his birds?

3. It will take Jordan $\frac{1}{2}$ a day to do the yard work around the house. He decides to spend $\frac{1}{3}$ of that time mowing the lawn. How much time does Jordan spend doing other yard work?

4. Anya needs to divide $\frac{2}{3}$ gallon of milk equally between her two friends. How much milk will each friend get?

5. Two-fifths of Troy's card collection are postcards. Of these cards, one third are from Boston and one-sixth are from New York. What fraction of Troy's cards are from Boston and New York?

6. If Troy decides to give one-fourth of his baseball cards to his brother and one-sixth of his baseball cards to his cousin, what fraction of his cards will he have left?

Homework Practice**5NS2.5***Multiplying Mixed Numbers***Multiply. Write in simplest form.**

1. $\frac{1}{2} \times 5\frac{1}{4}$ _____

2. $\frac{3}{5} \times 2\frac{2}{3}$ _____

3. $4\frac{3}{4} \times 2$ _____

4. $\frac{4}{9} \times 3\frac{2}{8}$ _____

5. $\frac{1}{2} \times 4\frac{2}{3} \times 3\frac{2}{5}$ _____

6. $1\frac{1}{3} \times \frac{5}{8} \times 9\frac{3}{4}$ _____

Evaluate each expression if $x = 3\frac{1}{3}$, $y = \frac{2}{3}$, and $z = 2\frac{3}{5}$.

7. $5y$ _____

8. $3z$ _____

9. $\frac{1}{3}z$ _____

10. $\frac{3}{4} \times 2\frac{2}{3} \times \frac{6}{7}$ _____

11. $\frac{1}{2} \times \frac{5}{6} \times 4\frac{6}{7}$ _____

12. You pay $\frac{1}{6}$ the price for apples as compared to mangoes. If mangoes are \$4.99 per pound, how much do you pay for apples per pound?

Spiral Review**Multiply. Write in simplest form.**

13. $\frac{1}{3} \times \frac{1}{2}$ _____

14. $\frac{1}{5} \times 50$ _____

15. $\frac{2}{5} \times \frac{5}{13}$ _____

16. $\frac{3}{4} \times \frac{2}{3}$ _____

17. $\frac{1}{8} \times 56$ _____

18. $\frac{7}{9} \times \frac{2}{3}$ _____

Problem-Solving Practice**5NS2.5***Multiplying Mixed Numbers***Multiply. Write in simplest form.**

- Erin usually walks $6\frac{3}{5}$ blocks for exercise. One day, she walks $1\frac{4}{11}$ times farther. How far did she walk?
- Felix collected $4\frac{3}{8}$ bags of trash along the highway. His friend Kenji picked up $2\frac{1}{5}$ times as much. How much trash did Kenji collect?

_____ blocks

_____ bags

- Aaron built a model of his favorite airplane. The length of the model is $1\frac{1}{4}$ times its width. If its width is $7\frac{1}{2}$ inches, how long is the model?
- Mr. Craig moved to a new house. He drove $4\frac{1}{8}$ miles to his job from his old house. From his new house, he has to drive $1\frac{3}{5}$ times farther. How far does he have to drive to work now?

_____ inches

_____ miles

- Chris collects rocks. She has 54 different types. Her friend Jenny has $1\frac{1}{3}$ times as many rocks as Chris has, and their friend Julie has $1\frac{1}{4}$ times as many as Jenny has. How many rocks does Julie have?
- David is planting an L-shaped vegetable garden. He measures the length and width of each section and draws the sketch below. Use his diagram to find the area of the garden. (Remember that area is found by multiplying length and width.)

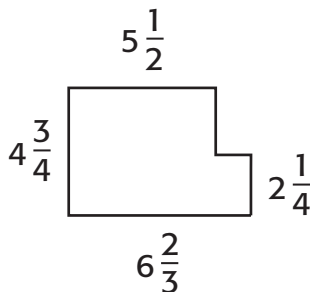

_____ square feet

Homework Practice

5NS2.5

*Dividing Fractions***Find the reciprocal of each number.**

1. $\frac{2}{3}$ _____

2. $\frac{7}{8}$ _____

Divide. Write in simplest form.

3. $\frac{1}{2} \div \frac{3}{4}$ _____

4. $\frac{3}{5} \div \frac{2}{3}$ _____

5. $\frac{3}{4} \div 2$ _____

6. $\frac{4}{9} \div \frac{2}{8}$ _____

7. $\frac{2}{3} \div \frac{2}{5}$ _____

8. $\frac{1}{3} \div \frac{5}{8}$ _____

Evaluate each expression if $x = \frac{2}{3}$, $y = \frac{1}{4}$, and $z = \frac{3}{4}$.

9. $y \div x$ _____

10. $z \div y$ _____

11. $3x \div z$ _____

12. You pay $\frac{1}{3}$ the price for beans as compared to pineapple. If pineapple is \$5.99 per pound, how much do you pay for beans per pound?

Spiral Review**Multiply.**

13. $1\frac{1}{2} \times 2\frac{3}{4}$ _____

14. $\frac{1}{8} \times 2\frac{1}{2}$ _____

15. $\frac{3}{4} \times 2\frac{5}{6}$ _____

16. $6\frac{1}{5} \times 3\frac{3}{4}$ _____

17. $\frac{3}{5} \times 2\frac{2}{3}$ _____

18. $3\frac{4}{5} \times 4\frac{1}{3}$ _____

Evaluate each expression if $a = 1\frac{1}{4}$, $b = 3\frac{1}{3}$, and $c = 2\frac{1}{2}$.

19. $\frac{3}{4}b$ _____

20. $\frac{1}{2}a$ _____

21. ac _____

Problem-Solving Practice**5NS2.5***Dividing Fractions***Divide. Write in simplest form.**

- Lynn made several pans of lasagna. Each piece is $\frac{1}{12}$ of a pan. How many pieces were in five pans of lasagna?
_____ pieces
- Chi feeds his cat $\frac{3}{4}$ cup of food each day. How many days can he feed his cat with 6 cups of food?
_____ days
- Zane made a recipe for a cake that requires 2 teaspoons of cinnamon. The only measuring spoon he had measures $\frac{1}{4}$ teaspoon. How many times must he use this measuring spoon to get the correct amount of cinnamon?
_____ times
- Leigh is planning a birthday party for her little sister. She bought 5 pounds of candy to fill a piñata. If each child at the party receives $\frac{1}{6}$ pound of candy, how many children will be at the party?
_____ children
- Steve made a fruit salad for dinner. The recipe called for 4 cups of apples, $2\frac{1}{2}$ cups of nuts, 2 cups of celery, and $\frac{1}{2}$ cup of raisins. If each person eats $\frac{1}{2}$ cup of the salad, how many people will the salad serve?
_____ people
- Anita is placing mulch around her trees and shrubs. She bought 20 pounds of mulch. If each tree or shrub requires $\frac{2}{3}$ pound of mulch, how many trees and shrubs can she mulch?
_____ shrubs and trees

Homework Practice**5NS2.5***Dividing Mixed Numbers***Divide. Write in simplest form.**

1. $6\frac{2}{3} \div \frac{7}{8}$ _____

2. $\frac{7}{8} \div \frac{1}{3}$ _____

3. $8 \div \frac{3}{4}$ _____

4. $5\frac{3}{5} \div \frac{2}{3}$ _____

5. $12 \div \frac{3}{4}$ _____

6. $\frac{4}{9} \div \frac{1}{8}$ _____

7. $3\frac{1}{2} \div 2\frac{2}{3}$ _____

8. $3\frac{1}{3} \div 4\frac{5}{8}$ _____

Evaluate each expression if $x = 6$, $y = 3\frac{4}{5}$, and $z = 1\frac{1}{2}$.

9. $y \div x$ _____

10. $x \div z$ _____

11. $\frac{1}{3}z$ _____

12. How many full $\frac{7}{8}$ pound jars of jelly can Alexa make from $9\frac{12}{13}$ pounds of jelly?
_____**Spiral Review****Divide. Write in simplest form. (Lesson 6-10)**

13. $\frac{3}{4} \div \frac{1}{2}$ _____

14. $\frac{3}{5} \div \frac{7}{8}$ _____

15. $\frac{1}{8} \div \frac{4}{5}$ _____

Find the value of each expression if $a = \frac{1}{4}$, $b = \frac{1}{2}$, and $c = \frac{2}{5}$.

16. $c \div a$ _____

17. $a \div b + c$ _____

18. $b \div c$ _____

Problem-Solving Practice**5NS2.5***Dividing Mixed Numbers***Divide.**

1. You are making bags of oranges. You have 3 baskets of oranges and each basket holds $2\frac{1}{8}$ pounds of oranges. How many bags can you make that are $\frac{1}{2}$ pound?

2. A farmer harvests $75\frac{5}{6}$ pounds of beans a day. The farmer works $8\frac{1}{3}$ hours each day. How many pounds of beans does he harvest each hour?

3. If you are laying out a photo page and have each photo cut to $3\frac{2}{5}$ inches wide, how many can you fit in a row that is $27\frac{1}{5}$ inches long? There are no spaces between the photos.

4. If you cut blankets from a piece of fleece that is $2\frac{1}{4}$ yard long, how many $\frac{3}{4}$ yard pieces will you cut?

5. How many $8\frac{3}{4}$ ounce steaks can you make from $61\frac{1}{4}$ ounces of meat?

6. If you drive $240\frac{1}{2}$ miles on your trip in $10\frac{3}{4}$ hours, how many miles per hour did you travel? Write in simplest form.

Homework Practice**5NS1.5***Ordering Integers***Replace each _____ with < or > to make a true sentence.**

1. -5 _____ 0 2. 25 _____ -15 3. 60 _____ 40 4. 12 _____ 10

5. 4 _____ -5 6. 19 _____ 18 7. -6 _____ -3 8. 75 _____ 90

9. -3 _____ -2 10. 83 _____ 59

Order each set of integers from least to greatest.

11. $14, 11, 2, 8, 9$ _____

12. $-50, 167, -240, 34, 17, 95$ _____

13. $-68, -113, 2, 89, 62, 7, -90$ _____

14. $7, 81, 5, 12, -5, 100, 64$ _____

15. $37, -90, 9, 16, 25, 432, -900$ _____

Solve.

16. Anya, Carolina, and Maria are all waiting for their trains to arrive. Anya's train will arrive at 11 A.M., Carolina's train will arrive at 11:30 A.M., and Maria's train will arrive an hour before Carolina's. Order the three by who will arrive first.
- _____

Spiral Review**Divide. Write in simplest form. (Lesson 6-11)**

17. $5\frac{3}{5} \div \frac{2}{3}$ _____

18. $12 \div \frac{3}{4}$ _____

19. $\frac{4}{9} \div \frac{1}{8}$ _____

Problem-Solving Practice**5NS1.5***Ordering Integers***Solve.**

1. Two people are waiting for their trains to arrive. The first person has to wait 23 minutes, and the second person has to wait 5 minutes. Who has the longest wait?

2. On Monday, in Maine the temperature fell to -20°F , and in Vermont the temperature fell to 0°F . Which state is colder?

3. Juan's test scores are: 100, 91, 98, 54, 75, 0. Order the set of scores from least to greatest.

4. On her test sheet, in the box marked **Number Wrong**, Olivia got a -10 and Yolanda got a -20 . Who has the lower score, Olivia or Yolanda?

5. At 7:00 A.M., the temperature was -9°C . At noon, the temperature was 0°C . At 6:00 P.M., the temperature was -10°C . At what time was the temperature the coldest?

6. In a go-cart race, Miguel's time was 50 seconds less than the average time. Danny's time was 30 seconds less than the average time. Who had the fastest time?

Homework Practice**5NS2.1***Adding Integers***Add.**

1. $+3 + (+4)$ _____

2. $+9 + (+8)$ _____

3. $6 + (-12)$ _____

4. $+9 + (+15)$ _____

5. $-7 + (+17)$ _____

6. $2 + (-1)$ _____

7. $+13 + (-4)$ _____

8. $+4 + (-7)$ _____

9. $-5 + (-15)$ _____

Solve.

10. The temperature outside is -2°F . If the temperature rises 2 degrees, what will the temperature be?

11. At halftime in a football game, team A has lost 16 yards (-16) and team B has lost 32 yards (-32). Which team has lost the least?

Spiral Review

Replace each _____ with $<$ or $>$ to make a true sentence. (Lesson 7-1)

12. -80 _____ 80

13. 6 _____ 5

14. -99 _____ 7

15. -8 _____ 0

16. -202 _____ -252

17. 12 _____ 8

18. -25 _____ -20

19. 75 _____ 85

20. 43 _____ -86

Order each set of integers from least to greatest.

21. $54, 52, -2, -8, 91$ _____

22. $-70, 22, -80, 34, 756, -965$ _____

23. $-4, -13, 2, -9, 52, 24, -90$ _____

Problem-Solving Practice**5NS2.1***Adding Integers***Solve.**

1. Before halftime in a football game, a team scored 21 points. After halftime, the team scored 6 more points. How many points did the team score?

2. The temperature outside is 80°F . If the temperature rises 10°F , what will the temperature be?

3. The temperature in Tahoe is -1°C . If the temperature falls 6°C , what will the temperature be?

4. Diego and Ana are playing a board game. They both start on the same square. Diego first moves forward 2 squares, and on his next turn he moves backward 1 square. On her first turn, Ana moves forward 6 squares, and on her next turn she moves forward 4 squares. Who is ahead?

5. Later in the game, Ana is forced to move back 10 squares, but then gains 1 square. How many squares did she move?

6. During the next 6 plays, Diego loses 12 squares, but he also gains 12 squares. How many squares does he gain?

Homework Practice**5NS2.1***Subtracting Integers***Subtract.**

1. $7 - 2$ _____

2. $-9 - (-5)$ _____

3. $-4 - (-4)$ _____

4. $-9 - 10$ _____

5. $-7 - (-3)$ _____

6. $0 - (-1)$ _____

7. $-15 - 8$ _____

8. $-9 - (-3)$ _____

ALGEBRA9. Evaluate $a - b$ if $a = 8$, and $b = 10$. _____10. Find the value of $m - n$ if $m = -5$, and $n = 10$ _____**Spiral Review****Add. (Lesson 7-2)**

11. $-7 + 2$ _____

12. $+9 + (-5)$ _____

13. $-4 + (-10)$ _____

14. $+9 + (-18)$ _____

15. $-7 + (-3)$ _____

16. $0 + (-1)$ _____

17. $+15 + 8$ _____

18. $-9 + (-3)$ _____

Solve.19. The temperature outside is 23°C . If the temperature drops 24 degrees, what will the temperature be?
_____20. At the start of a board game, with both players starting in the same square, Mary moved forward 8 squares and on her next turn backward 7 squares. On his first turn, Joe didn't move at all, but moved 2 squares on his second turn. Who is ahead?

Problem-Solving Practice**5NS2.1***Subtracting Integers***Solve.**

1. Jan receives \$15 every week for her allowance. She has to spend \$10 a week for lunches and \$2 a week to ride the bus. How much money does she have left each week?

2. One week, Jan got her usual \$15 allowance. She spent \$10 on lunches and \$2 to ride the bus. She wants to buy a hat for \$15. How much more money does Jan need?

3. Jose and Juan are contestants on a game show. Currently, Jose has 24 points, and Juan has -4 points. How many more points does Jose have than Juan?

4. Bernice ran a mile in 20 seconds more than her average time. Yesterday, she ran a mile in 10 seconds more than her average time. What is the difference between these times?

5. John earns \$40 every week by mowing grass. This week, he spent \$35 on sneakers. How much money does John have left?

6. John ran 5 miles every day the first week he started running. Now, he can run 10 miles every day. How many more miles can John now run each day?

Homework Practice**6NS2.3***Multiplying Integers***Multiply.**

1. $3 \times (-4)$ _____

2. $-9 \times (-8)$ _____

3. $6 \times (-12)$ _____

4. $-9 \times (5)$ _____

5. $-1 \times (-17)$ _____

6. $-2 \times (-10)$ _____

7. $12 \times (4)$ _____

8. $4 \times (-7)$ _____

9. -5×5 _____

10. $3 \times (-1)$ _____

ALGEBRA

11. Evaluate st if $s = -5$ and $t = 7$. _____

12. Find the value of ab if $a = -10$ and $b = -3$. _____

Spiral Review**Subtract. (Lesson 7-3)**

13. $12 - 2$ _____

14. $-7 - (-5)$ _____

15. $-14 - 4$ _____

16. $-8 - 5$ _____

17. $0 - (-8)$ _____

18. $-16 - (-1)$ _____

Solve.

19. Jim receives \$25 every week for his allowance. He has to spend \$10 a week for lunches and \$2 to ride the bus to his music lesson. How much does he have left?

20. One week, Jim received his usual \$25 allowance. He spent his usual \$10 for lunches and \$2 to ride the bus. Jim also bought a DVD for \$18. How much money did Jim need to borrow to buy the DVD?

Problem-Solving Practice**6NS2.3***Multiplying Integers***Solve.**

1. For the past 5 years, the population of a city has decreased by 16 people a year. What is the city's population loss in relation to 5 years ago?

2. Rey forgot his lunch money for the past 4 days and borrowed money from the cafeteria. If lunch costs \$2.25, write an integer to show his balance for the past 4 days.

3. Lina is reading a novel. She reads 29 pages each night for 6 nights. Write an integer to show the number of pages that Lina has read.

4. The temperature in Carla's city is decreasing. For the past 9 days, the temperature has decreased by 3 degrees Fahrenheit each day. Write an integer to show how much the temperature has decreased.

5. A public school loses 20 students each year due to transfers. If this pattern continues for the next 2 years, what will be the loss in relation to the original enrollment?

6. Ozzy and Paul discovered a buried treasure. For 10 days, they removed 5 cubic meters of dirt each day from the site. What integer represents the change in the amount of soil at the site?

Homework Practice**5MR1.1, 5NS2.1***Problem-Solving Strategy***Work Backward****Solve. Use the *work backward* strategy.**

1. A number is divided by 3. Next, 2 is subtracted from the quotient. Then, 4 is added to the difference. If the result is 12, what is the number?

2. Rey has \$5 in change after buying a hamburger for \$3.50 and a drink for \$1.50. How much money did Rey have originally?

3. Akiko is 5 years older than her brother Tai. Tai is 3 years older than their sister Kin. Kin is 6 years older than their brother Taro. If Taro is 15 years old, how old is Akiko?

4. Lina is 15 years older than Alberto. Alberto is 5 years older than Sonia. Sonia is 8 years older than Ernesto. If Ernesto is 5 years old, how old is Lina?

Spiral Review**Multiply. (Lesson 7-4)**

5. $10 \times (-2)$ _____

6. $3 \times (6)$ _____

7. $4 \times (-2)$ _____

8. $9 \times (-9)$ _____

9. $-16 \times (-1)$ _____

10. $-6 \times (-10)$ _____

11. $12 \times (-4)$ _____

12. $8 \times (-7)$ _____

13. -9×6 _____

14. $50 \times (-1)$ _____

Homework Practice**6NS2.3***Dividing Integers***Divide.**

1. $-10 \div 2$ _____

2. $42 \div 7$ _____

3. $36 \div (-6)$ _____

4. $-18 \div 2$ _____

5. $45 \div 9$ _____

6. $63 \div (-7)$ _____

7. $-15 \div 3$ _____

8. $49 \div 7$ _____

9. $-72 \div (-8)$ _____

10. $-24 \div 2$ _____

11. $40 \div 8$ _____

12. $-50 \div (-5)$ _____

ALGEBRA13. Find the value of $c \div d$ if $c = -30$ and $d = 3$.

14. What value of m makes $27 \div m = -9$ true?

Solve.

15. Karen lost a total of 10 points over the last 2 rounds of a game. If she lost the same number of points each round, what integer represents her change in score each round?

Spiral Review**Solve. Use the *work backward* strategy. (Lesson 7-5)**16. A number is multiplied by 10, and then -15 is added to the product. The result is 35. What is the number?

Problem-Solving Practice**6NS2.3***Dividing Integers***Solve.**

1. A football team was penalized a total of 30 yards in 3 plays. If the team was penalized an equal number of yards on each play, what integer represents the change in yardage for each penalty?

2. Over 6 years, the number of registered voters in Sequoia Heights declined by 2,400. If the decline in numbers was the same each year, what integer represents the change per year?

3. For the last 4 years, the average temperature of Clear Lake has dropped from 80°F to 72°F. If the decline in temperature was the same each year, what integer represents the change per year?

4. Carlos lost a total of 16 points over the last 2 rounds of a game. If he lost the same number of points each round, what integer represents the change in his score each round?

5. A plane starts above the clouds and then travels 50 feet toward the earth in 10 seconds. If the plane traveled an equal distance each second, what integer gives the change in altitude per second?

Homework Practice**5NR2.4, 5NS2.1***Problem-Solving Investigation***Use any strategy shown below to solve.**

- Logical reasoning
- Work backward
- Guess and check

1. Find the missing term in the pattern below.

..., _____, -6, -3, 0, 3, 6

2. Yolanda needs to be home at 4:00 P.M. It takes her 20 minutes to walk home, 20 minutes to say goodbye to her friends, and 10 minutes to organize her books and notebooks at school. What is the latest time she should start getting ready to come home?

Spiral Review Divide. (Lesson 7-6)

3. $12 \div 2$ _____

4. $60 \div (-6)$ _____

5. $24 \div (-6)$ _____

6. $-9 \div 3$ _____

7. $81 \div 9$ _____

8. $48 \div (-6)$ _____

9. $-35 \div 5$ _____

10. $64 \div 8$ _____

11. $-21 \div (-7)$ _____

ALGEBRA**12.** Find the value of $c \div d$ if $c = -32$ and $d = 4$.

13. What value of m makes $-9 \div m = -9$ true?

Homework Practice**5AF1.4***The Coordinate Plane*

Use the coordinate plane at the right. Identify the point for each ordered pair.

1. $(3, 4)$ _____ 2. $(-4, 3)$ _____
 3. $(-4, -4)$ _____ 4. $(-2, 2)$ _____

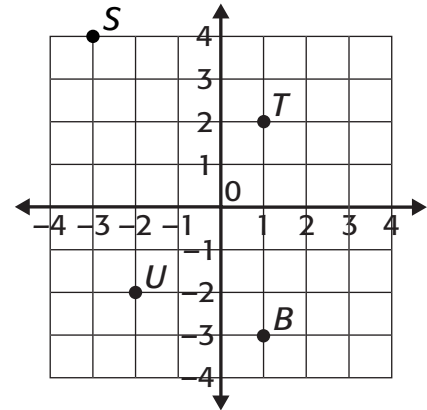

Write the ordered pair that names each point. Then, identify the quadrant where each point is located.

5. T _____ 6. S _____
 7. U _____ 8. B _____

Graph and label each point on a coordinate plane.

9. $N(2, 1)$ 10. $M(-3, -2)$ 11. $P(-3, 2)$ 12. $F(2, -2)$

Spiral Review

Use any strategy shown below to solve. (Lesson 7-7)

The four-step plan
 Logical reasoning
 Work backward
 Guess and check

13. Sean needs to be at practice at 10:00 A.M. every Saturday. It takes him 30 minutes to walk to practice, 30 minutes to get ready, and 10 minutes to organize his equipment. What is the latest time he should start getting ready for practice?
- _____

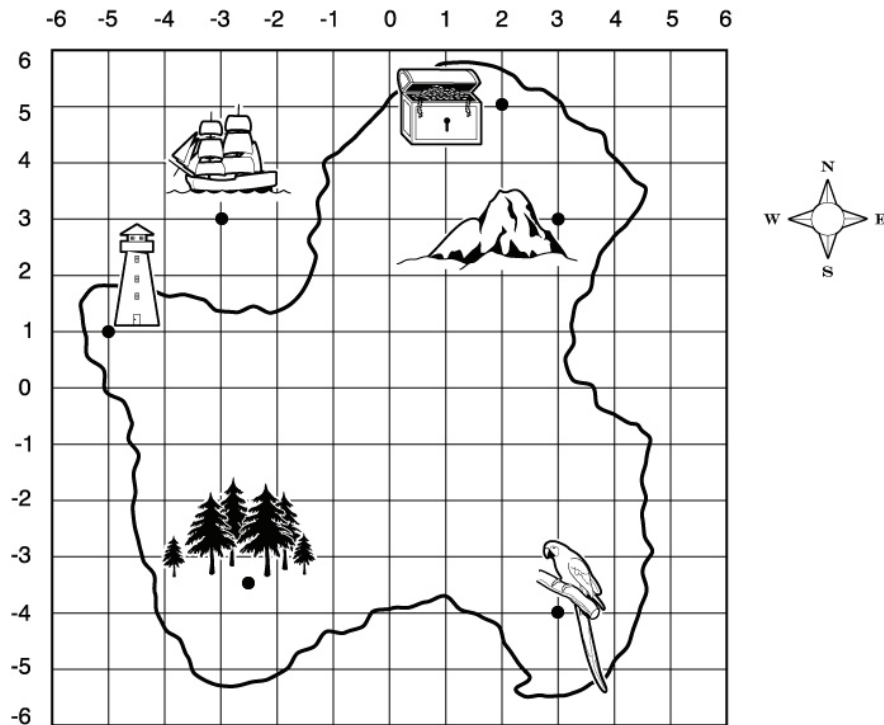
Problem-Solving Practice**5AF1.4***The Coordinate Plane*

1. What are the coordinates of the pirate ship? In which quadrant is it located?

2. What is located at the ordered pair $(-2.5, -3.5)$?

3. Begin at the lookout tower. Travel east 7 units and north 4 units. Where are you?

4. Which is the farthest south: the buried treasure, the mountain, or the parrot?

Homework Practice**5AF1.5***Solving Addition Equations***Solve each equation. Check your solution.**

1. $y + 4 = 8$ _____

2. $10 = 5 + d$ _____

3. $x + 2 = -12$ _____

4. $y + 7 = -16$ _____

5. $x + 0 = -1$ _____

6. $y + 3 = -8$ _____

7. $y + 9 = 18$ _____

8. $0 = 5 + d$ _____

9. $x + \frac{3}{4} = 3\frac{1}{2}$ _____

10. $5\frac{1}{2} = 5 + d$ _____

11. $x + 6 = -12$ _____

12. $-10.1 = 7 + d$ _____

13. $y + 6.9 = 2.6$ _____

14. $-3.9 = 2.3 + d$ _____

15. $x + 1.5 = 3$ _____

Solve.

16. Andrew weighs 94 pounds with his new boots on. Without them, Andrew weighs 92 pounds. Write and solve an addition equation to find the weight of the boots.
- _____

Spiral Review**Use the coordinate plane. Identify the point for each ordered pair. (Lesson 7-8)**

17. $(3, 4)$

18. $(-5, 3)$

19. $(-5, -4)$

20. $(-2, -2)$

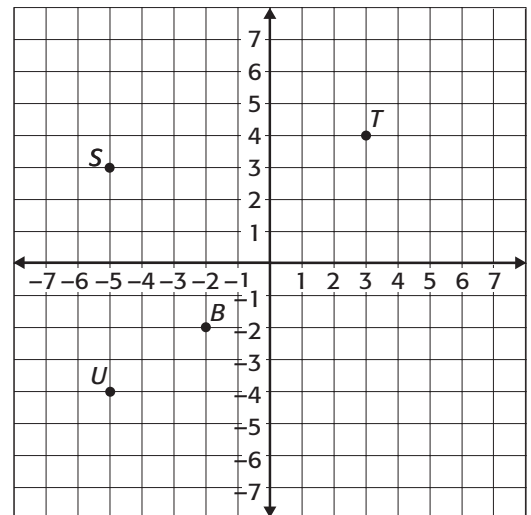

Problem-Solving Practice**5AF1.5***Solving Addition Equations***Write an equation to solve.**

1. Eugene's football team scored 17 points in a football game, 6 of which Eugene scored. How many points did the rest of the team score?

2. Dottie read her book on Wednesday and Thursday. If she read 27 pages on Wednesday and read 64 pages in all, how many pages did she read on Thursday?

Solve.

3. Margarita had to measure butter for a recipe. She did not want to measure it directly in a cup because some butter would stick to the side of it. She put $1\frac{1}{2}$ cups cold water into a measuring cup and added butter until the level of the water read 2 cups. How much butter did she measure?

4. Silas rode his bicycle 2.5 blocks to his friend's house. From there, the two boys rode the rest of the way to school. If it is 8.7 blocks from Silas's house to the school, how far is it from his friend's house to the school?

5. Flora had saved a total of \$24.85. She went to a department store and bought a pair of gloves and a hat that matched her winter coat. If the gloves cost \$6.85 and she had \$10.45 left over, what did the hat cost?

6. Diane's parents bought three boxes of tiles to replace the old tiles on their kitchen floor. Each tile is one square foot, and there are 30 tiles to a box. The kitchen floor is 78 square feet. How many tiles will they have left over?

Homework Practice**5AF1.5***Solving Subtraction Equations***Solve each equation. Check your solution.**

1. $y - 4 = 2$ _____

2. $5 = 5 - d$ _____

3. $-4 = 11 - d$ _____

4. $x - 8 = -3$ _____

5. $y - 4 = -7$ _____

6. $8 = 13\frac{1}{2} - d$ _____

7. $-3 = d - 9$ _____

8. $x - 6 = -1$ _____

9. $y - 1\frac{1}{2} = 2$ _____

10. $-4.2 = -7.5 - d$ _____

11. $x - 1.1 = 1.9$ _____

12. $-4.5 - x = -4$ _____

Solve.

13. The difference between record high and record low temperatures for August in New York City is 40°F . The record low is 60°F . Write and solve an equation to find the record high temperature of summer in New York City.

Spiral Review**Solve each equation. Check your solution. (Lesson 7-9)**

14. $y + 9 = 18$ _____

15. $-2.4 = 1.1 + d$ _____

16. $t + \frac{1}{2} = 9$ _____

17. $-12 = -6 + d$ _____

18. $x + 10 = -12$ _____

19. $m + -3 = 0$ _____

20. $s + 1.5 = 3$ _____

21. $25 = 5 + d$ _____

22. $x + 7 = -14$ _____

Solve.

23. Usually, running burns 300 more calories per hour than swimming does. If Emily burns 400 calories per hour running, write and solve an addition equation to find how many calories Emily will burn swimming.

Problem-Solving Practice**5AF1.5***Solving Subtraction Equations***Write an equation. Then solve.**

- Doug had 250 liters of soup to serve in the cafeteria. After lunch, 27 liters were left over. How much soup was served?

- Alisa and other students write articles for the school newspaper. The next issue of the newspaper will contain 87 articles. Alisa finished writing all of her articles, and now there are 75 articles left for the other students to write. How many articles did Alisa write?

- Ted has a choice of two summer camps, one of which is 26.7 miles from home and one that is 98.3 miles from home. How much farther is the second camp from Ted's home?

- Jaida and her sister shared a mushroom and pepperoni pizza. Jaida ate $\frac{1}{2}$ of the pizza. After her sister had some, there was $\frac{1}{6}$ of the pizza left. How much did her sister eat?

- Rosanne wanted to compare the amount of electricity she used in the summer to the amount she used in the winter. The reading on her electric meter at the first of January was 1587 kWh (kilowatt-hour) and the reading at the first of February was 1746 kWh. How many kWh did she use in January? _____ kWh

The following summer, the reading at the first of July was 2047 kWh, and the reading at the first of August was 2238 kWh. How many kWh did she use in July? _____ kWh

How many more kWh did she use in July than in January? _____ kWh
- Martin has birdhouses outside his home. When he checked them two weeks ago, three of them had bluebirds, four of them had sparrows, and the rest of them had martins. When he checked them last week, half of the houses that had martins had been taken over by blue jays. If he has 11 birdhouses, how many of them contained blue jays?

Homework Practice**5AF1.5***Solving Multiplication Equations***Solve each equation. Check your solution.**

1. $6b = 24$ _____

2. $-8m = -32$ _____

3. $49 = 7x$ _____

4. $2y = 10$ _____

5. $-1t = -12$ _____

6. $63 = 7x$ _____

7. $8a = 24$ _____

8. $-2s = -22$ _____

9. $54 = 6y$ _____

Solve.

10. Maria painted flowers on 10 plates and earned \$50. Write and solve an equation to find out how much she earned for each plate.
- _____

Spiral Review**Solve each equation. Check your solution. (Lesson 7-10)**

11. $y - 4 = 2$ _____

12. $-4 = -11 - d$ _____

13. $-4.5 - x = -4$ _____

14. $x - 8 = -3$ _____

15. $y - 4 = -7$ _____

16. $8\frac{1}{2} = 13\frac{1}{2} - d$ _____

17. $-5 = d - 10$ _____

18. $t - 9\frac{1}{2} = -4\frac{1}{2}$ _____

19. $-1.1 = -10.5 - d$ _____

Solve.

20. Joe is 3 inches shorter than his brother Jack. Jack is 60 inches tall. Write and solve an equation to find out how tall Joe is.
- _____

Problem-Solving Practice**5AF1.5***Solving Multiplication Equations***Write an equation. Then solve.**

1. Samantha has 7 tomato plants in 12 rows. How many tomato plants does she have?

2. If Calah cuts 16 pizzas into 8 slices each, how many total slices will she have?

3. Olivia raises 12 chickens on her farm. If each chicken lays 20 eggs in two weeks, how many eggs will she gather?

4. Juan works a total of 5 hours at his after-school job. If he earns \$7 per hour worked, how much does he earn altogether?

5. Sophia has a large family. There are 8 people sitting at each of 6 tables. When they all get together for a holiday dinner, how many people are there?

6. Jacob likes to go on nature walks. On one of his walks, he noticed 5 different types of insects. He also saw 2 types of plants and 1 lizard. His walk covered only 1 acre. If he walked over 4 acres, how many things might he have seen?

Homework Practice**6NS1.2***Ratios and Rates*

Write each ratio as a fraction in simplest form. Then explain its meaning.

1. A teacher has 15 minutes each day to teach handwriting and 40 minutes each day to teach spelling. What is the ratio of time spent teaching handwriting to time spent teaching spelling?

2. A theatre club has 5 boys and 10 girls. What is the ratio of boys to girls?

3. On Saturday, there are 10 trains leaving from a train station, and there are 25 planes leaving from an airport. What is the ratio of trains to planes?

Write each rate as a unit rate.

4. \$12 for 4 lunch meals

5. 92 miles in 2 hours

Spiral Review

Solve each equation. Check your solution. (Lesson 7-11)

6. $2x = 24$ _____

9. $6t = 12$ _____

7. $-4m = -24$ _____

10. $-5s = -60$ _____

8. $81 = 9x$ _____

11. $56 = 7x$ _____

Problem-Solving Practice**6NS1.2***Ratios and Rates***Solve.**

1. The ratio of red marbles to green marbles is 2 to 3. Write this ratio two other ways.

2. Miriam can read 120 pages in 3 hours. How many pages can she read in 1 hour?

3. Darcy exchanged 10 U.S. dollars and received 15 New Zealand dollars. How many New Zealand dollars would she get for 50 U.S. dollars?

4. Alisha and Sandra are playing checkers. There are 7 red checkers and 10 black checkers left on the board. What is the ratio of black checkers to the total?

5. Russ gives Juliana a bag of marbles and tells her that the ratio of red marbles to the total number is 3 to 19. He also tells her there are 3 times as many yellow marbles as red, and that there are 2 more green than red. What is the ratio of yellow marbles to green?

6. When Robbie walks 10 feet, he takes 7 steps. How many steps would he take if he walked 100 yards? How many steps would he take if he walked 1 mile?

7. Angie spends 10 minutes each day talking on her cell phone and Sandy spends 45 minutes talking on her cell phone. What is the ratio of the time Angie spends talking on her cell phone to the time Sandy spends talking on her cell phone? Write it in simplest form.

8. Joseph ran the marathon in 5 hours. If a marathon is about 25 miles and Joseph ran at a constant rate, how many miles per hour did Joseph run?

Homework Practice**5MR1.1, 5NS2.1***Problem-Solving Strategy***Solve. Use the *look for a pattern* strategy.**

- 1. ALGEBRA** Describe the pattern below. Then, find the missing number. 50, 500, _____ 50,000

- 2.** Joe is stacking cans of fruit in a triangular form for a display. The top row has 2 cans, the second row has 4 cans, and the third row has 8 cans. How many cans will be on the fifth row? _____

- 3.** Write a problem that can be solved by looking for a pattern. Then solve the problem.

Spiral Review

Write each ratio as a fraction in simplest form. Then explain its meaning. (Lesson 8-1)

- 4.** A dance class has 8 boys and 16 girls. What is the ratio of boys to girls?

- 5.** On Saturday, there are 5 trains leaving from a station in Philadelphia and going to New York City, and there are 25 buses going from Philadelphia to New York City. What is the ratio of trains to buses leaving Philadelphia and going to New York City?

- 6.** A bookstore has 48 graphic novels and 72 short story collections. What is the ratio of graphic novels and short story collections?

Homework Practice**5MR2.3, 5NS2.1***Ratio Tables***Use the ratio tables given to solve each problem.**

1. To make 2 glasses of orange juice, you need 20 oranges. How many oranges do you need to make 6 glasses of orange juice? _____

| | | | |
|--------------------------|----|----|---|
| Number of Oranges | 20 | 40 | |
| Number of Glasses | 2 | 4 | 6 |

2. The science museum requires that 3 adults accompany every 30 students. How many adults must accompany 150 students? _____

| | | | | |
|---------------------------|----|----|-----|-----|
| Number of Students | 10 | 30 | 120 | 150 |
| Number of Adults | 1 | 3 | 12 | |

3. Sonya bought 6 cases of bottled water for \$24. How much will Sonya pay to buy 4 more cases of bottled water? _____

| | | | | |
|-------------------------------|-----|-----|------|---|
| Cost | \$4 | \$8 | \$12 | |
| Cases of Bottled Water | 1 | 2 | 3 | 4 |

4. Sherri purchased 500 beads for \$25 to make bracelets. If she needs 100 more beads, how much will she pay if she is charged the same rate? _____

| | | | | |
|------------------------|-------|-----|------|------|
| Cost | \$.05 | | \$10 | \$25 |
| Number of Beads | 1 | 100 | 200 | 500 |

Spiral Review**Solve. Use the look for a pattern strategy. (Lesson 8-2)**

5. **ALGEBRA** Describe the pattern below. Then find the missing number.

20, 60, _____, 540 _____

6. Joe is stacking boxes of sneakers in stacks on shelves. The first shelf holds stacks of 8, and the second shelf holds stacks of 6. How many stacks of sneakers will be on the fourth shelf? _____

7. In 2000, Jack earned \$1,200 for the year and Eddie earned \$600 for the year. In 2001, Jack earned \$1,800 and Eddie earned \$1,400. If the amount of money that each earns increases by the same amount, what year will they be earning the same amount of money? _____

Problem-Solving Practice**5MR2.3, 5NS2.1***Ratio Tables***Use ratio tables to solve each problem.**

1. Before leaving for a school trip to Spain, Matt traded 500 U.S. dollars and received 250 euros. When he returned from Spain, he had 50 euros left. How much will he receive when he exchanges these euros for dollars?

2. Apples are on sale at 10 for \$2. Find the cost of 36 apples.

3. Before administering a medicine, a veterinarian needs to know an animal's weight in kilograms. If 20 pounds is about 9 kilograms and a dog weighs 40 pounds, what is the dog's weight in kilograms? Explain your reasoning.

4. If a hummingbird were to get all of its food from a feeder, then a 16-ounce nectar feeder could feed about 80 hummingbirds a day. How many hummingbirds would you expect to be able to feed with a 4-ounce feeder?

5. A patient receives 2 milliliters of antibiotic every 4 hours. At that rate, how many hours will it take to receive 20 milliliters of antibiotic?

6. Luis won a peanut eating contest by eating 4,800 peanuts in 4 hours. If he ate at a constant rate, how many peanuts had he eaten after 3 hours?

Homework Practice**5AF1.5***Equivalent Ratios*

Determine if the quantities in each pair of ratios or rates are equivalent. Explain your reasoning.

1. \$15 for 5 books; \$35 for 7 books

2. \$20 for 10 sandwiches; \$100 for 50 sandwiches

3. \$12 for 4 roses; \$30 for 6 roses

4. 950 miles driven on 50 gallons of fuel; 840 miles driven on 24 gallons of fuel

Spiral Review

For Exercises 5–6, use the ratio tables given to solve each problem. (Lesson 8-3)

5. To make 6 servings of baked potato skins, you need 18 potatoes. How many potatoes do you need to make 15 servings of baked potato skins?

| | | | |
|---------------------------|----|--|----|
| Baked Potato Skins | 6 | | 15 |
| Number of Potatoes | 18 | | |

6. The aquarium requires that 5 adults accompany every 50 students. How many adults must accompany 200 students?

| | | | |
|-----------------|----|--|-----|
| Students | 50 | | 200 |
| Adults | 5 | | |

Problem-Solving Practice**5AF1.5***Equivalent Ratios*

Determine if the quantities in each pair of rates are equivalent. Explain your reasoning.

1. Mai spent \$2.50 to make 5 prints from her digital camera. Later, she went back to the same store and spent \$5 to make 10 more prints.

2. The Drama Club raised \$52 by selling 26 fresh muffins. The Chess Club raised \$36 by selling 18 fresh muffins.

3. The Exercise Club raised \$100 by selling 20 exercise CDs. The Hiking Club raised \$200 by selling 20 nature walk CDs.

4. Soto can do 100 push-ups in 5 minutes. Steven can do 120 push-ups in 6 minutes.

5. One school survey showed that 4 out of 5 students take the bus to school. Another survey showed that 6 out of 10 students take the bus to school.

6. Koko enlarged a photograph to 6 inches by 9 inches. Will it fit well in a frame that is 12 inches by 9 inches if she puts 3-inch matting around the photograph?

Homework Practice**5MR2.3, 5SDAP1.1***Problem-Solving Investigation***Use any strategy shown below to solve each problem.**

- Act it out
- Look for a pattern
- Make a table

- 1.** Frank completed 3 passes the first year that he played football, 5 the second year, and 7 the third year. At this rate, how many passes should he expect to complete by his sixth year playing football?

- 2.** To train for the Math League competition, Janice spent $\frac{1}{2}$ hour each day of the first week reviewing lessons, adding an additional $\frac{1}{2}$ hour each week for 4 weeks. What were the total number of hours she spent reviewing during the fourth week?

- 3.** The table below shows the amount of snow in Maine for 4 weeks during January. What is the mean amount of snow that fell during the month of January?

| | | | | |
|-------------------|----|----|----|----|
| Week | 1 | 2 | 3 | 4 |
| Snow (in.) | 21 | 28 | 29 | 22 |

Spiral Review**Determine if the quantities in each pair of ratios or rates are equivalent. Explain your reasoning. (Lesson 8-4)**

- 4.** \$5 for 10 notebooks; \$40 for 8 notebooks

- 5.** \$9 for 3 rolls of film; \$30 for 15 rolls of film

Homework Practice**5AF1.1, 5AF1.2***Algebra: Ratios and Equations***Solve.**

1. $\frac{2}{3} = \frac{x}{9}$ _____

2. $\frac{1}{5} = \frac{x}{10}$ _____

3. $\frac{y}{4} = \frac{1}{2}$ _____

4. $\frac{6}{8} = \frac{x}{48}$ _____

5. $\frac{5}{25} = \frac{x}{5}$ _____

6. $\frac{15}{45} = \frac{1}{t}$ _____

7. $\frac{20}{4} = \frac{5}{p}$ _____

8. $\frac{1}{7} = \frac{x}{49}$ _____

Spiral Review**Use any strategy shown below to solve each problem. (Lesson 8-5)**

- Look for a pattern
- Act it out
- Make a table

9. Andrew is taking a picture of the group of 5 crossing guards. The group leader must be in the middle of the group with 3 crossing guards on either side of him. How many different ways can Andrew arrange the crossing guards for the picture?

10. Tonya took a survey of the number of pencils students bring to school each week. Which is greater for this set of data, the mode or the median?

Number of Pencils

6, 4, 2, 3, 1, 6, 0, 7, 5, 1, 1, 0, 7, 4, 4, 2, 1, 3, 7, 6

11. Trina and her mother drove 110 miles to visit her grandmother. They drove 30 miles an hour for the first 60 miles and then 50 miles an hour for the rest of the trip. How many hours did it take them to complete the trip?

Problem-Solving Practice**5AF1.1, 5AF1.2***Algebra: Ratios and Equations***Solve.**

1. A florist is using carnations to make bouquets for each table in a restaurant. He has used 24 carnations for 3 bouquets. There are 27 tables in the restaurant. Write an equation to express the relationship between the 24 carnations for 3 bouquets and the number of carnations c needed for 27 tables. Then solve.

2. A recent survey reported that out of 200 middle school students, 120 said that they read at least one news story in the newspaper every day. At this rate, how many out of 600 middle school students would you expect to read at least one news story in the newspaper every day?

3. Jim spent \$51 on 3 CDs. At this rate, how much would 8 CDs cost?

4. Suppose 5 out of every 30 students get on the honor roll. Predict how many students will get on the honor roll in a school system of 1,200 students.

5. This past Saturday, a free ticket to the circus was placed on the back of every fifth sales receipt. If there were 7,200 sales receipts given out, how many people got a free ticket to the circus?

6. After selling tickets for 2 hours, the circus company had already sold 450 tickets. If tickets continue to sell at this rate for the next 3 hours, how many more tickets will the circus company sell?

Homework Practice**5AF1.2, 5AF1.5***Algebra: Sequences and Expressions*

Use words and symbols to describe the value of each term as a function of its position. Then find the value of the tenth term in the sequence.

1.

| | | | | | |
|----------------------|----|----|----|----|-----|
| Position | 2 | 3 | 4 | 5 | n |
| Value of Term | 10 | 15 | 20 | 25 | |

2. There are 60 minutes in 1 hour. Make a table and write an algebraic expression relating the number of hours to the number of minutes. Then find the number of minutes Lucas spent exercising if he exercised 6 hours.

| | | | | | |
|----------------|--|--|--|--|--|
| Hours | | | | | |
| Minutes | | | | | |

Spiral Review**Solve. (Lesson 8-6)**

3. $\frac{6}{12} = \frac{x}{2}$ _____

4. $\frac{3}{24} = \frac{1}{y}$ _____

5. $\frac{y}{16} = \frac{2}{32}$ _____

6. $\frac{5}{8} = \frac{x}{40}$ _____

7. $\frac{5}{45} = \frac{x}{9}$ _____

8. $\frac{18}{72} = \frac{1}{t}$ _____

9. $\frac{30}{6} = \frac{5}{p}$ _____

10. $\frac{21}{7} = \frac{x}{1}$ _____

Problem-Solving Practice*Algebra: Sequences and Expressions***Write an algebraic expression to solve.**

1. There are 3 feet in 1 yard. Write an algebraic expression relating the number of feet in a yard. Then find the length of a field in yards if it is 60 feet long.

2. There are 24 hours in 1 day. Write an algebraic expression relating the number of hours to the number of days. Then find the number of hours in 5 days.

3. It costs \$12 an hour to rent a colonial costume. Write an expression to find the amount charged for renting a costume for n hours. Then use the expression to find out how much it would cost to rent a costume for 5 hours.

4. A student is charged \$0.50 for every day a library book is overdue. Write an expression to find the amount charged for returning a book n days overdue. Then use the expression to find out how much it would cost to return a book 10 days overdue.

5. The label says there are 6 grams of protein in one cup of ice cream. Write an algebraic expression relating the grams of protein to the number of cups. Then find the amount of protein in 3 cups of ice cream.

Homework Practice**5AF1.1, 5AF1.5***Algebra: Equations and Graphs***Write an equation to represent the function displayed in the table.**

1.

| | | | | | |
|-------------------------------|---|----|----|----|----|
| Input, x | 1 | 2 | 3 | 4 | 5 |
| Output, y | 5 | 10 | 15 | 20 | 25 |

Use the following information for Exercises 2–4.

In a video game, each player earns 10 points for every coin he or she collects.

2. Make a table to show the relationship between the number of coins collected, c and the total points, p . Graph the results on a coordinate grid.

| | | | | |
|--|--|--|--|--|
| Number of coins, c | | | | |
| Total points, p | | | | |

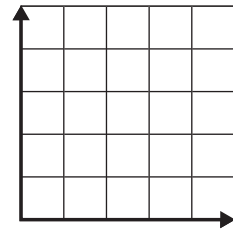

3. Write an equation to find p . _____
4. How many points will a player earn if he or she collects 9 coins? _____

Spiral Review**Solve. (Lesson 8-7)**

5. There are 60 minutes in 1 hour. Write an algebraic equation relating the number of hours to the number of minutes. Then find the duration of the movies in hours if Liz and her friends watched two movies that together were 270 minutes long.

Problem-Solving Practice**5AF1.1, 5AF1.5***Algebra: Equations and Graphs***Write an equation to represent the function displayed in the table.**

| | | | | |
|---------------------------|-----|-----|-----|-----|
| Hours Walking Dogs | 1 | 2 | 3 | 4 |
| Earnings (\$) | \$2 | \$4 | \$6 | \$8 |

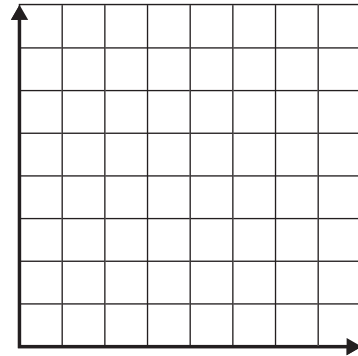

1. The table shows the amount of money Yvonne earns based on the number of hours she walks dogs. Write a sentence and an equation to describe the data. Then find the total earnings for 6 hours, 7 hours, and 8 hours. Graph the results on a coordinate grid.

2. The basketball team is holding a car wash to raise money. They are charging \$8 for each car they wash. Make a table to show the relationship between the number of cars washed, c and the total amount earned, t . Graph the results on a coordinate grid. Then, write an equation to find the total amount earned, t for washing cars, c .

| | | | |
|--------------------------------------|-----|---|---|
| Cars Washed, c | 1 | 2 | 3 |
| Amount Earned, t | \$8 | | |

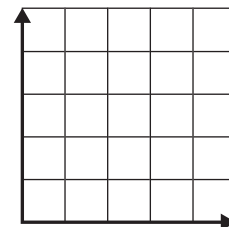

3. While in normal flight, a hawk flies at an average speed of 10 miles an hour. Make a table to show the relationship between the total distance, d that a hawk can travel in, h hours. Then, write an equation to find the total distance, d that a hawk can travel in, h hours while in normal flight. Graph the results on a coordinate grid.

| | | | | |
|---------------------------------|----|---|---|---|
| Hours, h | 1 | 2 | 3 | 4 |
| Distance, d | 10 | | | |

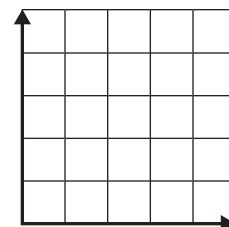

Homework Practice**5NS1.2, 5SDAP1.3***Percents and Fractions*

Write each percent as a fraction or mixed number in simplest form.

1. 22% _____

2. 7% _____

3. 146% _____

4. 465% _____

Write each fraction or mixed number as a percent.

5. $\frac{8}{10}$ _____

6. $\frac{5}{20}$ _____

7. $1\frac{4}{5}$ _____

8. $2\frac{2}{5}$ _____

Write a percent to represent the shaded portion of each model.



Spiral Review

Use the following information for exercises 11–13. (Lesson 8–8)

A squirrel eats at the rate of 2 pounds of acorns each day.

11. Make a table to show the relationship between the number of pounds of acorns eaten, a , by a squirrel in d days.

12. Write an equation to find a , the number of pounds of acorns a squirrel eats in d days .

13. How many pounds of acorns will a squirrel eat in 7 days?

Problem-Solving Practice**5NS1.2, 5SDAP1.3***Percents and Fractions***Solve.**

1. The shaded part shows the percent of Tina's class who are left-handed. Write the percent.

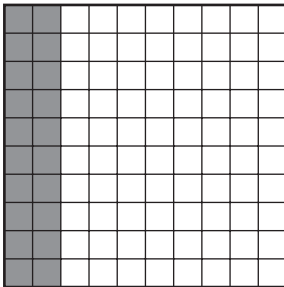

2. In William's school, 60% of the students are girls. Write 60% as a fraction in simplest form.

3. Edward found that $\frac{35}{100}$ of the students in his school bring their own lunch to school. Write this fraction as a percent.

4. Lindsey drew a 10-by-10 grid and colored 42 squares red. She colored the rest of the squares green. What percent of the grid is colored red?

What percent is colored green?

5. Kory used yellow, green, blue, and red markers to color all the squares of a 10-by-10 grid. He colored 12 squares blue, then colored twice as many red. There are three times as many red squares as yellow squares. If the rest of the squares are green, is more than half the grid colored green? What percent of the grid is not colored yellow or green?

6. Linda is making a design using a 10-by-10 grid. She drew stars in 50% of the squares. In half of the remaining squares, she drew triangles. Half the squares containing stars were colored yellow. What fraction of the grid is not colored and does contain a star or triangle?

Homework Practice**5SDAP1.2, 5SDAP1.3***Circle Graphs*

1. Sketch a circle graph beside the table that shows the number of students who went on the following field trips.

| Field Trip Location | Percent of Students |
|---------------------|---------------------|
| Aquarium | 27 |
| Museum | 19 |
| Science Center | 9 |
| Zoo | 15 |
| Water Park | 18 |
| Mountain Hike | 12 |

2. Which field trip location had the most students?

3. Which two field trips made up about half of the total students?

Spiral Review

Write each percent as a fraction or mixed number. (Lesson 9-1)

4. 15% _____

5. 117% _____

Write each fraction or mixed number as a percent.

6. $\frac{3}{20}$ _____

7. $\frac{70}{100}$ _____

Problem-Solving Practice**5SDAP1.2, 5SDAP1.3***Circle Graphs***Solve.**

1. Luis drew a circle graph of the food types he likes best. If fruit makes up 40% of the graph, fruit makes up what fraction of his favorite foods?

2. Casey found out that chocolate ice cream is preferred by 12% of the students in his class. About what fraction of a circle graph would be used for chocolate ice cream on a circle graph that shows favorite ice cream flavors?

3. Randy knows that 36% of the adults in his neighborhood work in a nearby city. About what fraction of a circle graph would show adults who work in a nearby city?

4. Kathy works at a fast-food restaurant. Twenty-five percent of the food they sell is hamburgers, 35% is chicken, 18% is French fries, and the remainder is salads. About what fraction of a circle graph would represent the salads sold?

5. Stacy took a test that included 10 multiple-choice questions, 12 true-false questions, 14 short-answer questions, and 4 essay questions. If she used a circle graph to show the question types on the test, about what part of the circle graph would represent the number of short-answer questions?

6. Heather looked at a circle graph that showed age groups of the people in her small town. On the graph 17% is used for ages 0 to 4, 14% for ages 5 to 12, 20% for ages 13 to 20, 22% for ages 21 to 50, and 12% for ages 51 to 65. The remainder of the graph represents people who are older than 65. What percent of the people in her town are older than 65?

Homework Practice**5NS1.2***Percents and Decimals***Write each percent as a decimal.**

1. 23% _____

2. 37% _____

3. 3% _____

4. 105% _____

Write each decimal as a percent.

5. 0.7 _____

6. 0.44 _____

7. 0.64 _____

8. 1.08 _____

Fill in each circle with $<$, $>$, or $=$ to make a true sentence.

9. 3.4 341% _____

10. 0.2 18% _____

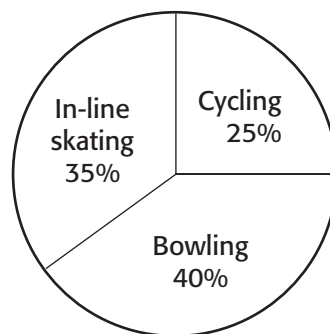
Spiral Review**For Exercises 11–12, use the graph below. (Lesson 9-2)****Favorite Family Sports**

11. The circle graph shows favorite family sports. What percent of the families prefer in-line skating or cycling?

12. What percent of the families prefer bowling?

Problem-Solving Practice**5NS1.2***Percents and Decimals***Solve.**

1. The Park High Panthers won 25% of their basketball games this year. Write the percent as a fraction in simplest form.

2. In Culver City, 45% of the roads need repair. Write the percent as a decimal.

3. In Joseph's neighborhood, 32% of the homes have the local newspaper delivered. Write the percent as a decimal and as a fraction in simplest form.

4. George has read 18 of the 50 books in his bookcase. What percent of the books has George read? Write the percent as a decimal and as a fraction in simplest form.

5. Mr. Simons gave his history students three quizzes. On the first quiz, Ryan got 12 of the 15 questions correct. On the second quiz, he got 15 of the 20 questions correct, and on the third, 21 of 25 questions were correct. On which quiz did he score the highest percent?

6. The Raiders won 8 of their football games this season. They played a total of 12 games, and had the same number of losses as ties. The Spartans won 10 of their 15 games, and had one less tie than loss. Which team had the higher percent of games lost?

Homework Practice**5MR2.2, 5NS1.2***Problem-Solving Strategy***Solve. Use the *solve a simpler problem* strategy.**

1. Sawa spent \$28.95 on her meal, and she wanted to leave a 15% tip. If she paid \$35.00 and received \$1.71 back in change, how much did she leave for a tip? If she left a 20% tip and paid \$35.00, how much change would she get back?
-

2. Sam has a piece of string 40 inches long. He needs to cut it into 4-inch long pieces. How many cuts will he make if he uses all 40 inches?
-

3. **Bus Line**

| Route | Number of Passengers |
|-----------|----------------------|
| Northeast | 2,800 |
| Northwest | 2,300 |
| North | 2,400 |

There are 3 routes on the bus line. About how many total passengers are there? Which route is the most traveled?

Spiral Review**Write each percent as a decimal. (Lesson 9-3)**

4. 45% _____

5. 32% _____

6. 164% _____

Homework Practice**5MR2.2, 5NS2.5***Estimating with Percents***Estimate each percent.**

1. 32% of 99 _____
2. 23% of 149 _____
3. 9% of 248 _____
4. 49% of 202 _____

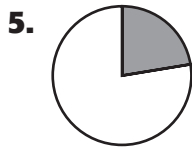
Estimate the percent that is shaded.

7. If you see a hat on sale for 45% off, and the hat is \$24.99, estimate the sale price.
- _____

Spiral Review**Solve. Use the *solve a simpler problem* strategy. (Lesson 9-4)**

8. If your dog needs to be walked 5 times a day, how many times does it need to be walked in a week?
- _____

9. Jamie's mom wants to leave a 25% tip for a \$38.50 restaurant bill. About how much money should she leave?
- _____

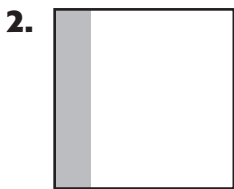
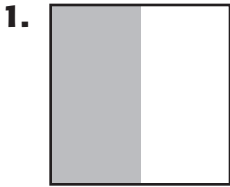
Problem-Solving Practice**5MR2.2, 5NS2.5***Estimating with Percents***Estimate each shaded area and write your answer as a percent.****Estimate.**

3. Savannah wants to save 30% of her allowance. If her allowance is \$35 a month, about how much should she save per month?
-

4. According to a recent survey, about 42% of kids say they don't get enough sleep. Out of a school with 978 kids, predict the number who would say they do get enough sleep.
-

5. There are about 10 percent more boys born for every girl born in the world. Predict the number of boys that will be born if the number of girls born is 98,877.
-

6. You buy a jacket that is priced at \$125. It is on sale for 45% off. About how much will you pay for the jacket?
-

Homework Practice

5NS1.2

*Percent of a Number***Find the percent of each number.**

1. 20% of 160 _____
2. 9% of 27 _____
3. 110% of 80 _____
4. 55% of 150 _____

Solve.

5. You are shopping and see a 70% off clearance sale. If the original price on the sweatshirt is \$27.50, what is the sale price?

6. If the sales tax for question 5 above is 6%, what is the amount of tax?

Spiral Review**Estimate each percent. (Lesson 9-5)**

7. 19% of 98 _____
8. 75% of 31 _____
9. 34% of \$91 _____
10. 78% of 345 _____
11. Estimate the area of your yard if it is 31 feet by 19 feet.

Problem-Solving Practice**5NS1.2***Percent of a Number***Solve.**

- Noah bought a shirt that was on sale for 80% of its regular price of \$20.99. To the nearest cent, what was the sale price?

- Roberto took a test that contained 25 questions. He received an 88% on the test. How many questions did he answer correctly?

- Hillary uses propane as a fuel to heat her home. When the gas company comes to fill the 500-gallon tank, they add propane until the tank is 85% full. After a delivery, how many gallons of propane are in the tank?

- Barbara's class was investigating methods used to heat homes in her town. She reported that 35% of the homes are heated by electricity. If there are 546 homes in her town, how many homes are heated by electricity? Round off your answer to the nearest whole number.

- Shanta shopped for new clothes. She found the best deal at Gillian's Department store, where clothes were 90% of their original cost. A few days later these new prices were reduced by another 10%. How much did she pay for a jacket that originally cost \$115.00? Write your answer to the nearest penny.

- Chelsea plays on a softball team that has won 75% of its games. Her sister Catrina plays on a softball team that has won 80% of its games. If Chelsea's team has played 28 games, and Catrina's team has played 25 games, which team won more games? How many more games did they win?

Homework Practice**5MR1.1, 5NS1.2***Problem-Solving Investigation***Choose the Best Strategy****Use any strategy shown below to solve.**

- Look for a pattern.
- Work backward.
- Solve a simpler problem.

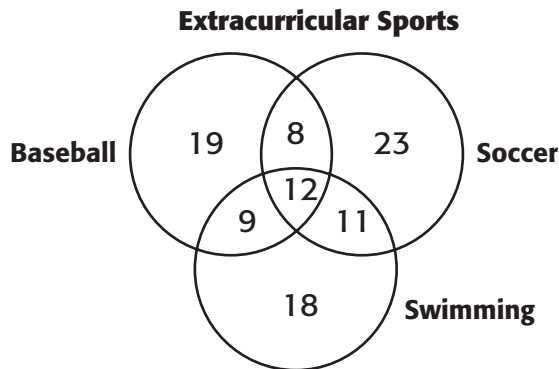
Use the following Venn diagram to answer questions 1–3.

1. How many total people played soccer?

2. How many people played only soccer and baseball?

3. How many swam and played baseball only?

4. How many played baseball, swam, and played soccer?

5. How many people only swam and played soccer?

Spiral Review**Find the percent of each number. (Lesson 9-6)**

6. 6% of 56

7. 60% of 60

Solve.

8. What is 20% of 465?

9. 36% of 234 is what number?

Homework Practice**6SDAP3.3***Probability*

The bag of cubes that is shown contains 4 stars, 2 fives, and 1 striped cube. You will pick only one cube. Find each probability. Write the answer as a fraction and a percent rounded to the nearest whole number.

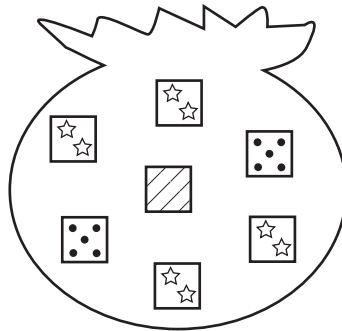
1. $P(\text{star})$

2. $P(\text{stripe})$

3. $P(\text{not a stripe})$

4. $P(\text{star or stripe})$

Spiral Review

Use any strategy shown below to solve. (Lesson 9-7)

- Look for a pattern.
- Work backward.
- Solve a simpler problem.

5. The softball team has won 4 times as many games as they lost. If they lost 6 games, how many games did they play?

Problem-Solving Practice**6SDAP3.3***Probability***Solve.**

1. What is the probability that Lindy will roll a number divisible by 3 on a number cube?

2. How would you describe the probability that Adrian will roll the number 7 on a number cube?

3. Wayne went to a banquet. At the end of the meal, equal numbers of pieces of blueberry, apple, and cherry pie were passed out randomly to the dinner guests. What is the probability that Wayne will receive apple pie? What is the probability that he will receive either apple or cherry pie?

4. Lavonne's mother has brown eyes, and her father has blue eyes. Lavonne has brown eyes, and her husband has blue eyes. She knows that her children are equally likely to have brown or blue eyes. What is the probability that her first child will have blue eyes? If her first child has brown eyes, what is the probability that the second child will have blue eyes?

5. Sara has a spinner divided into 12 sections. Each section is numbered, starting with 1 and ending with 12. Sara spins the spinner. What is the probability that she will spin a prime number? What is the probability that she will spin an odd number? What is the probability that she will spin a number divisible by 5? What is the probability that she will spin a multiple of 3? What is the probability that she will spin a multiple of 4 or 5?

6. Eduardo cleaned out his school locker. At the bottom of the locker, he found 5 pencils with erasers, 1 pencil missing its eraser, 2 red pens, 3 black pens, and 4 blue pens. He placed all these items in a box and mixed them up. If he closes his eyes and picks one item out of the box, what is the probability that it is a pencil? What is the probability that it is a pen? What is the probability that it is a pencil with an eraser or a black pen?

Homework Practice**6SDAP3.1***Sample Spaces***Make an organized list or tree diagram to show the sample space.**

1. How many choices do you have for your lunch if you pick either ham or roast beef with cheese, tomatoes, or onions to go on your sandwich?

2. You go to a playground. You decide to climb across the monkey bars, go down the slide, and climb the rock wall. How many different ways can you complete your choices?

3. You are getting ready for school, and you only have a choice of white, black, or yellow shoes and either a pair of jeans or shorts. How many possible combinations can you have?

Spiral Review (Lesson 9-8)

Use the spinner below to answer questions 4 and 5. Find each probability. Write the answer as a fraction and a percent rounded off to the nearest whole number.

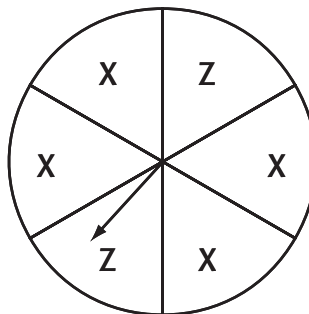

4. $P(X)$

5. $P(Z)$

Problem-Solving Practice**6SDAP3.1***Sample Spaces*

Use the spinners below for Exercises 1–5. Draw a tree diagram for each exercise and tell the outcomes that are possible. Spin them only once.

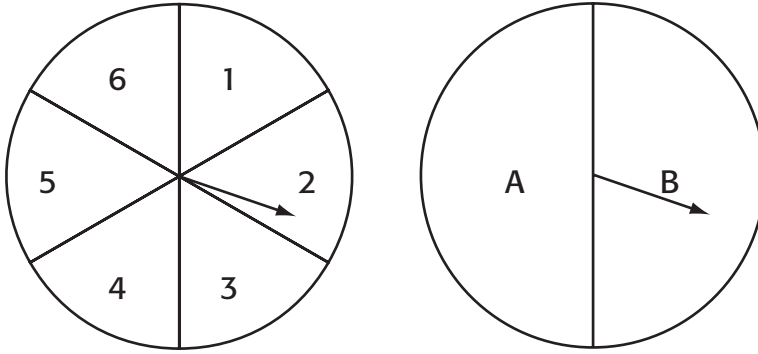

1. How many outcomes are possible for spinning both spinners?

2. $P(1, A)$

3. $P(\text{even number, consonant})$

4. $P(\text{not 3, vowel})$

5. $P(1 \text{ or } 6, A)$

Homework Practice**6SDAP3.2***Making Predictions***For Exercises 1 and 2, use the following information.**

On a quiz show, a contestant correctly answered 9 of the last 12 questions.

1. Find the probability of the contestant correctly answering the next question.

2. Suppose the contestant continues on the show and tries to correctly answer 24 questions. About how many questions would you predict the contestant to correctly answer?

Spiral Review (Lesson 9-9)

Use the spinners below to answer questions 3-6. Use a tree diagram to find each probability. Write the answer as a fraction and a percent rounded to the nearest whole number.

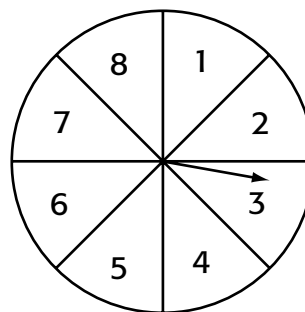
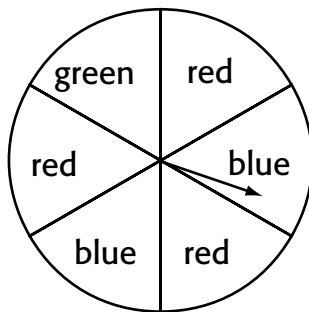

3. $P(\text{red, 2 or 3})$

4. $P(\text{green, odd number})$

5. $P(\text{blue, less than 5})$

6. $P(\text{not green, greater than 4})$

Problem-Solving Practice**6SDAP3.2***Making Predictions*

For Exercises 1–3, use the table of results of Jeremy’s survey of favorite kinds of movies.

| Favorite Movie Type | |
|---------------------|--------|
| Type | People |
| Drama | 12 |
| Foreign | 3 |
| Comedy | 20 |
| Action | 15 |

- How many people did Jeremy use for his sample?

- If Jeremy were to ask any person to name his or her favorite type of movie, what is the probability that it would be comedy?

- If Jeremy were to survey 250 people, how many would you predict would name comedy?

For Exercises 4–7, use the table of results of the Better Sleep Council’s survey of Americans to find the most important factors for good sleep.

| Most Important Factors for Good Sleep | |
|---------------------------------------|----|
| Good Mattress | 32 |
| Daily Exercise | 20 |
| Good Pillows | 8 |
| Healthy Diet | 11 |
| Other Factors | 29 |

- Predict how many people out of 400 would say that a good mattress is the most important factor.

- What is the probability that any person chosen at random would not say that a healthy diet is the most important factor?

- Suppose 250 people were chosen at random. Predict the number of people that would say good pillows are the most important factor.

- What is the probability that any person chosen at random would say that daily exercise is the most important factor for good sleep?

Homework Practice

5MG2.1

Measuring Angles

Use a protractor to find the measure of each angle. Then classify each angle as *acute*, *obtuse*, *right*, or *straight*.

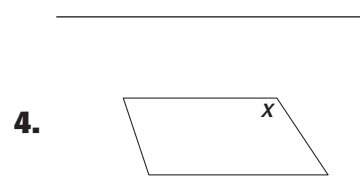
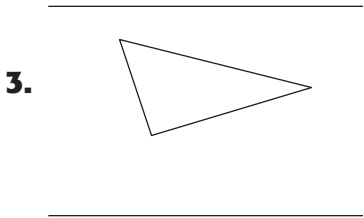
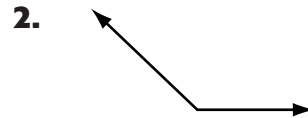
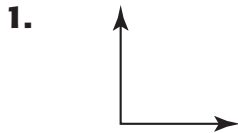

Use the picture to answer Exercises 5 and 6.

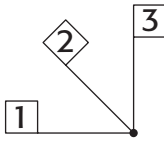

5. What is the measurement between flags 1 and 2?

6. What is the measurement between flags 1 and 3?

Spiral Review

For Exercises 7 and 8, use the following information. (Lesson 9-10)

Alex won 10 of her last 15 softball games.

7. Find the probability of Alex winning her next game.

8. Suppose Alex plays 75 games. Predict how many she will win.

Problem-Solving Practice**5MG2.1***Measuring Angles***Solve.**

- Kyle ate a small slice of pizza. Was the angle made by the cuts on the slice more likely 30° or 130° ?

- Guadalupe drew a triangle and labeled the vertices A , B , and C . If $\angle ABC$ is one of the angles in the triangle, what are the other two angles?

- Logan drew a ray on a graph. Its endpoint was at $(1, 2)$, and the ray passed through the point $(6, 2)$. He drew another ray that had the same endpoint and passed through $(4, 5)$. What is the measure of the angle formed?

- Kaoru drew several different regular polygons. He measured one of the angles inside one of the figures and found that its measure was 108° . Classify the angle as *acute*, *right*, or *obtuse*.

- Jordan was concerned that a local playground is not accessible to children with disabilities. So, she and her parents built a ramp over the steps at the entrance to the playground. The ramp must be at a 12° angle with the ground. The steps are 1.5 feet high. What is the approximate length of the ramp? Use a piece of graph paper and a protractor to help you. Let the side length of each square grid on the graph paper represent one foot.

- Derrick and his 7 brothers shared a fruit pie. Their mother cut the pie into 8 equal pieces. What was the angle formed at the point of each slice?

Homework Practice**5MR2.3, 5MG2.1***Problem-Solving Strategy***Solve. Use the *draw a diagram* strategy.**

1. You want to fill your yard with flowers. If you have a yard that is 8 feet by 12 feet, and every 6 square feet you want to add a flower, how many flowers will you plant?

2. You want to fill a bulletin board with your classmates' artwork. If the bulletin board measures 10 feet by 4 feet and you have 45 pieces of artwork that each measures 12 inches \times 12 inches to hang, how many pieces of work will *not* fit on the board?

3. The cafeteria serves breakfast. Study the chart below, and tell how many breakfast combinations you could order.

| Breakfast | Drink |
|-----------|-------|
| Muffin | Milk |
| Bread | Juice |
| Fruit | Water |

4. You decide to go to the Farmer's Market to buy some fruit. They have bags of peaches on sale for \$8.95 and cartons of raspberries for \$5.95. You buy two of each. How much will you spend altogether?

Spiral Review

Use a protractor to find the measure of each angle. Then classify each angle as *acute*, *obtuse*, *right*, or *straight*. (Lesson 10-1)

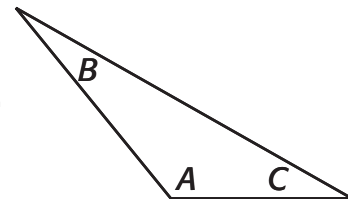

5. angle A

6. angle B

7. angle C

Homework Practice**5MG2.1***Estimating and Drawing Angles***Estimate the measure of each angle.**

1.

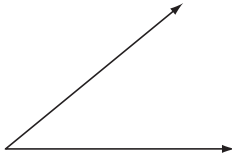

3.

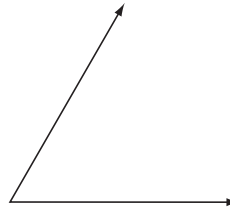

2.

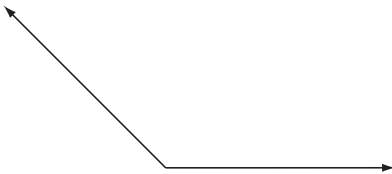

4.

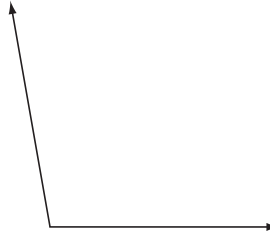

Use a protractor and a straightedge to draw angles having the following measurements.5. 155°

6. 75°

7. Look at the letter Y. Estimate the measure of the angle inside the upper part of the Y.

Spiral Review**Solve. Use the *draw a diagram* strategy. (Lesson 10-2)**

8. You have a paper money and coin collection. Your new display frame has room for one coin and one piece of paper money. How many different combinations of paper money and coin can you display in the frame if you have 5 coins and 3 pieces of paper money?

Problem-Solving Practice**5MG2.1***Estimating and Drawing Angles***Solve.**

1. Estimate the angle formed by the two flag poles.

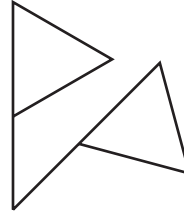

2.

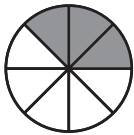

Estimate the angle formed by the shaded part of the circle.

3. When you write, what angle does your pencil form with the paper?

4. When your spoon is resting in a bowl, what angle does it form with the bottom of the bowl?

5. In the space below, draw a flower stem that has a leaf. Measure the angle that the leaf forms with the stem.

Homework Practice

5MG2.1

Parallel and Perpendicular Lines

Use the figure to determine if each pair of lines is *parallel*, *perpendicular*, or *neither*.

1. \overline{AB} and \overline{CD}

2. \overline{BD} and \overline{CD}

3. \overline{AD} and \overline{CD}

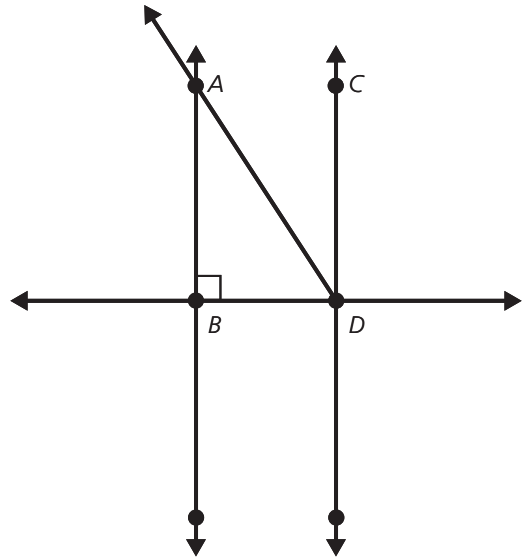

Find the value of x in each figure.

4.

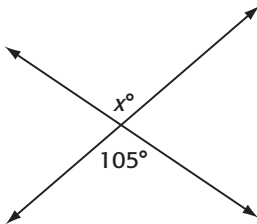

5.

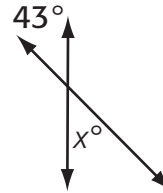

Spiral Review

Solve. Use a protractor and a straightedge to draw angles having the following measurements. (Lesson 10-3)

6. 33°

7. 109°

8. 130°

Problem-Solving Practice**5MG2.1***Parallel and Perpendicular Lines*

Use the figure below to determine if each pair of lines is *parallel*, *perpendicular*, or *neither*.

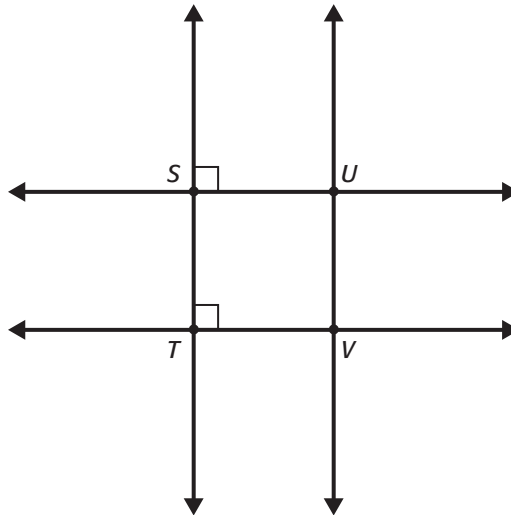

1. \overline{ST} and \overline{UV}

2. \overline{SU} and \overline{UV}

3. \overline{TV} and \overline{UV}

4. Draw a line parallel to \overline{SU} .

5. What lines will be perpendicular to your new line?

6. Sit in a chair with your feet flat on the floor. What angle does your lower leg form with your upper leg? Is your lower leg perpendicular or parallel to the floor?

Homework Practice**5MR1.1, 5MG2.1***Problem-Solving Investigation***Use any strategy shown below to solve each problem.**

- Look for a pattern
- Draw a diagram
- Guess and check

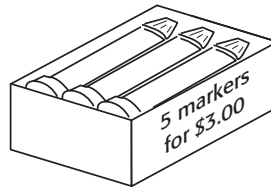
Use the picture to answer Exercises 1–3.

1. Compare the 2 containers of markers. Which is the better buy?

2. If you bought 1 of the first box and 3 of the second box, and you gave the cashier three \$5 bills, how much change would you get back?

3. You buy four boxes of markers and it costs you \$16. Which kind did you buy?

Spiral Review

Determine whether the statement is *sometimes*, *always*, or *never* true. Explain your reasoning. (Lesson 10-4)

4. Parallel lines are also perpendicular.

Homework Practice**5MG2.1, 5MG2.2***Triangles*

Classify each triangle drawn or having the given angle measures as *acute, right, or obtuse*.

1.

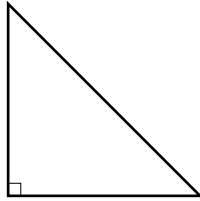

2.

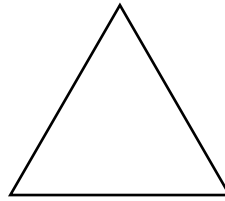

3. $70^\circ, 60^\circ, 50^\circ$

Find the value of x in each triangle. Then classify each triangle as *scalene, isosceles, or equilateral*.

4.

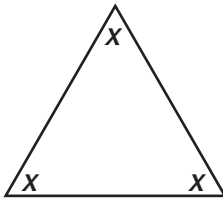

5.

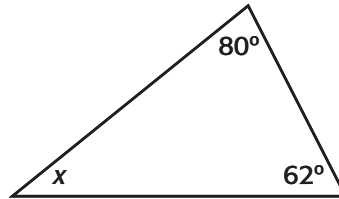

6.

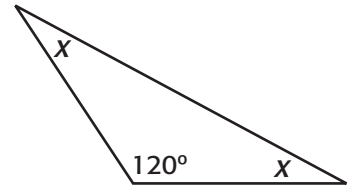

Spiral Review

Use any strategy shown below to solve. (Lesson 10-5)

- Look for a pattern
- Draw a diagram
- Guess and check

- 7.** In August Daryl ran 3 miles every other day. In September, he ran 3.5 miles every other day, and if the trend continues, how much will he run in October?

Problem-Solving Practice**5MG2.1, 5MG2.2***Triangles***Solve.**

1. Kendall found that two angles of a triangle were 68° and 86° . What is the measure of the third angle? What type of triangle is it?

2. Tomeka measured the angles of a triangle and found two of them to be 38° and 52° . What is the measure of the third angle? What type of triangle is it?

3. Martin hit a softball from home plate to center field. The center-fielder threw the ball to the first-base person, who threw it back to home plate. What type of triangle did the path of the ball form? Draw a diagram of a softball diamond to help you.

4. Steve has three lengths of fence. He connects them to make a triangular pen for his dog. If the lengths are 5 meters, 6 meters, and 10 meters, what type of triangle is the dog pen?

5. Kate planned a trip using a road map. She will travel northeast from her house to a city that is 240 miles away. Then she will drive southeast to visit her uncle. On the way from the city to her uncle's house, she will stop at a store 125 miles from the city and then continue in a straight line to her uncle's house, which is 115 miles from the store. Then, she will travel west to go home from her uncle's house. On her way home, she will stop at a state park that is 45 miles from her uncle's house and 195 miles from her house. Assuming she travels in a direct and straight path, what type of triangle is formed by her path?

6. Miguel has a ladder with legs of equal length. He opened the ladder and placed it on the floor. Classify the type of triangle formed by the ladder and the floor according to its sides. Next, classify the type of triangle formed by the ladder and the floor according to its angles.

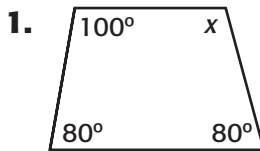
Homework Practice**5MG2.1, 5MG2.2***Quadrilaterals***Find the value of x in each quadrilateral.**

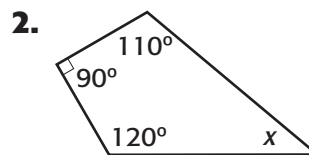

3. $75^\circ, 85^\circ, 115^\circ, x$

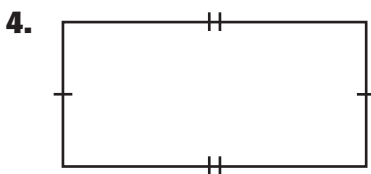
Classify each quadrilateral.

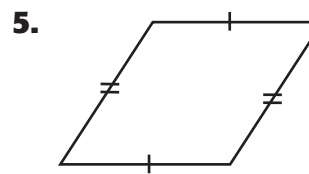

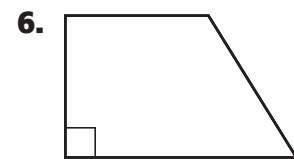

Spiral Review**Find the value of x in each triangle having the given angle measures. (Lesson 10-6).**

7. $100^\circ, 40^\circ, x^\circ$

8. $45^\circ, 100^\circ, x^\circ$

9. $75^\circ, 30^\circ, x^\circ$

Classify each triangle having the given angle measures as *acute*, *right*, or *obtuse*.

10. $120^\circ, 30^\circ, 30^\circ$

11. $70^\circ, 20^\circ, 90^\circ$

12. $65^\circ, 45^\circ, 70^\circ$

Problem-Solving Practice**5MG2.1, 5MG2.2***Quadrilaterals***Solve.**

- Linda drew a quadrilateral with angles of 90° , 42° , and 135° . What is the measure of the remaining angle?

- Natasha's yard is a square. If one side of her yard is 55 feet, what is the perimeter of her yard?

- Luisa creates her art project in the shape of a rhombus. If she measures two of the angles and they are 50° and 130° , what must the other two angles measure?

- Tim has a disagreement with his friend, Jan. Jan's yard is 20 meters long and 20 meters wide. Tim's yard is 40 meters long and 10 meters wide. Both yards contain only right angles. Tim says that his yard is both a rectangle and a square. Jan says the same thing about her yard. Who is correct? Explain your answer.

- Tomoko made a kite for a trip to the beach. She sketched a model of the kite on a piece of graph paper first. The points forming the vertices of the kite were $(0, 9)$, $(4, 13)$, $(8, 9)$, and $(4, 0)$. Was the kite in the shape of any special quadrilaterals? Explain your answer. Graph the points to help you solve.

- Tomoko is going to ship the kite in Exercise 5 to the beach. She can only ship it in a rectangular box. If the model of the kite was made on graph paper with squares that were 1 centimeter on a side, and the actual kite was 10 times the size of the model, what are the lengths of the sides of the rectangular box she must use?

Homework Practice**5MG2.3***Drawing Three-Dimensional Figures***Draw a top, a side, and a front view of each figure.**

1.

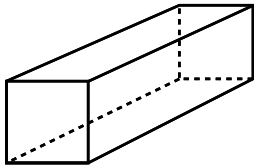

2.

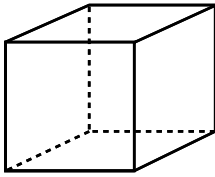

3.

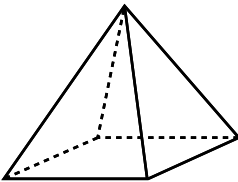

4.

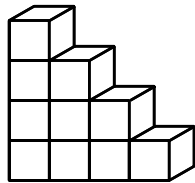

Spiral Review**Find the value of x in each quadrilateral. (Lesson 10-7)**

5. $65^\circ, 125^\circ, 80^\circ, x$

6. $85^\circ, 65^\circ, 105^\circ, x$

7. $90^\circ, 90^\circ, x^\circ, 90^\circ$

8. $120^\circ, 60^\circ, 120^\circ, x^\circ$

Problem-Solving Practice**5MG2.3***Drawing Three-Dimensional Figures***Solve.**

1. Ricardo made a model of the earth. What kind of three-dimensional figure is it?

2. Diane bought a can of soda. What kind of three-dimensional figure is the can?

3. Gary is playing a board game. When it is his turn, he tosses a kind of three-dimensional figure that is used in many board games. The figure is 6-sided and has a number printed on each side. What kind of figure is it?

How many faces, edges, and vertices does it have?

4. When Ben bought a poster, the salesperson placed it in a tube to protect it. What kind of three-dimensional figure is the tube?

If the tube is slit down its side and laid flat, what shapes would it make?

5. Anna is thinking of a three-dimensional figure. Its top view is a square. Its front and side views are triangles. What is the figure?

6. The Department of Defense headquarters is called the Pentagon. It is a pentagonal prism. Draw a top, front, and a side view of the Pentagon.

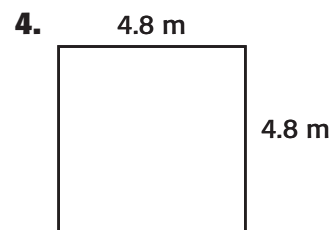
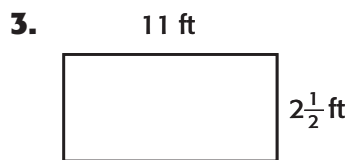
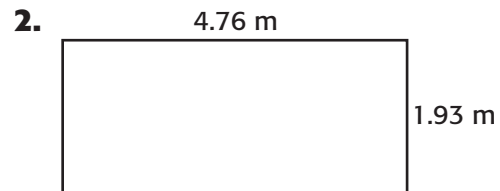
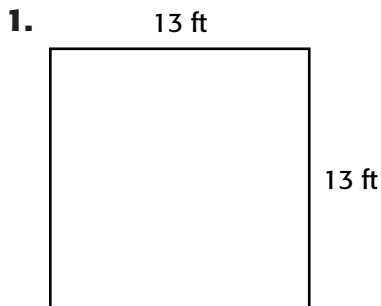
Homework Practice**5MG1.4***Perimeter***Find the perimeter of each square or rectangle.**

5. Neil made a wooden, rectangular picture frame that is 14 inches long and 10 inches wide. If he charges \$2.50 per foot, how much will he sell this frame for?
- _____

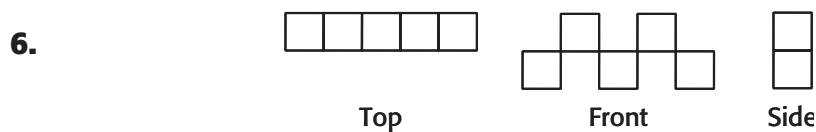
Spiral Review**Draw a three-dimensional figure whose top, front, and side views are shown. (Lesson 10-8)**

Problem-Solving Practice**5MG1.4***Perimeter***Solve.**

1. Hannah wants to create a fenced enclosure for her dog. To figure out how much fencing she needs, Hannah made a drawing of the enclosure.

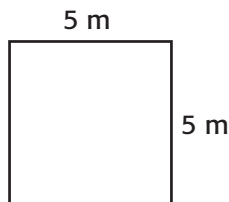

How much fencing will she need?

2. Johanna has a garden that is in the shape of a regular pentagon. Each side of the pentagon is 7 ft long. She decides to place a small, decorative wood fence around the perimeter. The fencing is sold in boxes of 5 pieces. Each piece has a length of 18 in. How many boxes of fencing will Johanna need to buy?
- _____
3. A driveway is 40 ft long and 14 ft wide. What is the perimeter of the driveway?
- _____
4. Tara has a rectangular garden that is 10 ft long and 4 ft wide. She wants to put a small fence around it. If fencing costs \$1.50 per ft, how much will the fence cost?
- _____
5. Vincent is designing a rectangular garden. The outside of the garden will measure 12 ft long and 5 ft wide. He plans to use tiles around the inside edge of the border. The tiles are squares, and each side measures 1 ft. After placing the tiles, Vincent will put a small fence around the inside, against the tiles. How many feet of fencing does he need?
- _____

Homework Practice**5MG1.1, 5MG1.4***Area of Parallelograms***Find the area of each parallelogram.**

1.

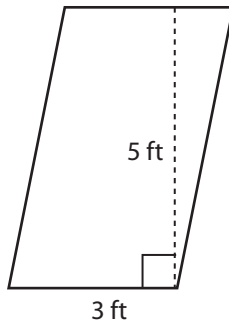

2.

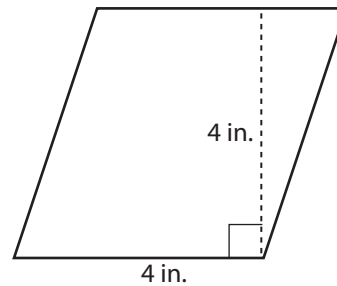

3. What is the area of a parallelogram with a base of 20 inches and a height of 8.5 inches?

Spiral Review**Find the perimeter of each square or rectangle. (Lesson 11-1)**

4.

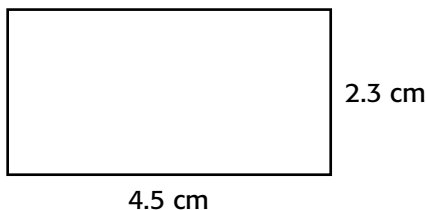

5.

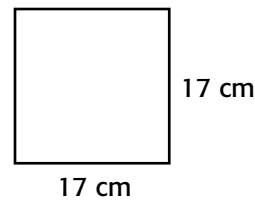

6. What is the measurement of z if the perimeter of the rectangle is 30 cm?

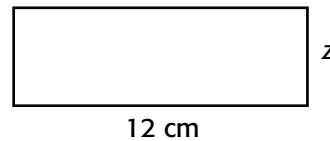

Problem-Solving Practice**5MG1.1, 5MG1.4***Area of Parallelograms***Solve.**

1. Tina is making a bulletin board in the shape of a parallelogram. She drew a diagram of the board. What is the area of Tina's bulletin board?

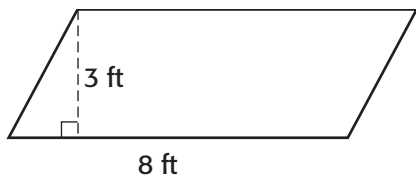

3. The after-school Explorers Club has designed its club sign in the shape of a parallelogram. The outline of the sign is shown in the diagram below. What is the area of the sign?

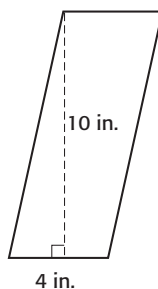

5. Rachel found the area of a parallelogram with a height of 6 in. and a base of 9 in. She draws an identical parallelogram side-by-side to it. What is the total area of the 2 parallelograms?

2. Sheri is designing a poster for geography class. She needs 7 parallelograms, one for each continent. If each parallelogram has a base of 10 in. and is 8 in. high, what is the total area of the 7 parallelograms?

4. For a science project, Kevin made 9 parallelograms. On each one, he will write facts about an animal. Each parallelogram has a base of 12 in. and is 6 in. high. About what size poster board should he buy so all 9 parallelograms will fit with some space around each? Assume the parallelograms are not rectangles and write your answer in square feet.

6. Refer back to exercise 4. Kevin found a poster board on sale. It measures 1.5 ft by 2 ft. Will the 9 parallelograms fit on it?

Homework Practice**5MR2.3, 5MG1.4***Problem-Solving Strategy***Solve. Use the *make a model* strategy.**

- Nan and Sato are designing a coffee table using 4 inch tiles. Nan uses 30 tiles and Sato uses half as many. How many total tiles did they use? If the area of the table is 36 inches by 26 inches, will they have enough tiles for the table? If not, how many more will they need?

- The Jones family is landscaping their yard. If they have a yard that is 160 square feet, and one side is 10 feet long, what is the length of the other side of the garden? If they plant 3 bushes that need to be 3 feet apart and 3 feet away from the fence around the yard, will they have the space?

- Derek is organizing a shelf in his closet. The shelf is rectangular and measures 18 inches long and 14 inches wide. Each box to be placed on the shelf is 9 inches long and 7 inches wide. How many boxes can he fit in one layer on the shelf?

- Roberto wants to build a brick wall. Each brick layer is 3 inches thick, and the wall will be 18 inches tall. How many layers will it have?

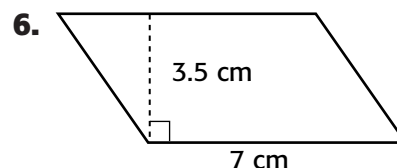
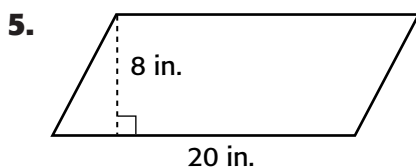
Spiral Review**Find the area of each parallelogram. (Lesson 11-2)**

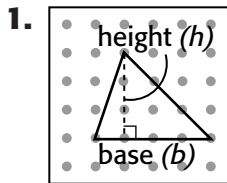
Homework Practice**5MG1.1, 5MG1.4***Area of Triangles***Find the area of each triangle.**

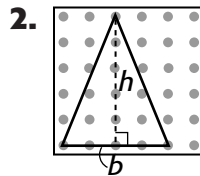

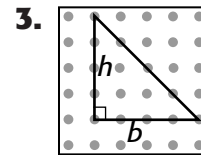

4. What is the area of a triangular table that has a base of 3 feet and a height of 2 feet?

5. Etsuko made a wooden, triangular picture frame that has a base of 15 cm and a height of 25 cm. What is the area?

Spiral Review**Solve. Use the *make a model* strategy. (Lesson 11-3)**

6. Kendra's little sister is making a pyramid out of wooden blocks. The bottom layer has 7 blocks. There is one less block in each layer, and there are 7 total layers in the pyramid. How many blocks does Kendra's sister use in all?

7. Vito folded a piece of construction paper in half 5 times. Then he cut a hole through all the layers. How many holes will there be when he unfolds the paper?

Problem-Solving Practice**5MG1.1, 5MG1.4***Area of Triangles***Solve.**

1. Oliver divided a parallelogram with an area of 28 in^2 into two identical triangles. What is the area of each triangle?

2. Aleta and her twin brother will have a birthday party. She baked a cake that measured 10 in. by 14 in. She divided it into two equal triangles. What was the area of each triangle?

3. Marian and her sister planted a rectangular vegetable garden that was 18 ft long and 20 ft wide. Her sister agreed to take care of half of the garden in exchange for half the vegetables. They divided the rectangle diagonally, forming two identical triangles. What is the area of each triangle?

4. Antonia has just enough paint to paint a 28 in^2 area. If she is painting a triangle design that has a base of 8 in. and a height of 6 in., will she have enough paint? Explain your answer.

5. Al is using a tent that has straight walls. It has support ropes that stretch from the top of the side wall to a peg in the ground. The tent is 6 ft tall. The triangle formed by the side of the tent, the rope, and the ground has an area of 12 ft^2 . How far is the peg from the bottom of the tent?

6. Mindy likes to sit on the top row of bleachers at the football games. The end of the bleachers form a triangle with an area of 112 ft^2 . The bottom row of the bleachers is 14 ft from the back of the bleachers. How high above the ground is Mindy sitting?

Homework Practice**5MR2.3, 5MG1.4***Problem-Solving Investigation***Use any strategy shown below to solve. Tell what strategy you used.**

- Make a model
- Draw a diagram
- Look for a pattern

- 1.** The Humane Society is building new cages for their dogs and cats. They have 2 crews of workers building them. There are 28 dogs and 34 cats. All the animals are kept separate. The first crew can build a cage in 1 hour and the second crew, which is smaller, takes 2 hours to build a cage. How many hours will it take to build the cages using both crews if they do not take a break?
- _____

- 2.** A coach needs to inform his 30 players that practice is cancelled. He calls the first player and tells him to call 2 more of his teammates and tell each of them to call two more teammates and so on until everyone is informed. How many players make phone calls?
- _____

- 3.** Marge needs to bake 8 dozen cookies for a bake sale. For each batch of cookies she needs $4\frac{1}{2}$ cups of flour. Each batch makes 2 dozen cookies. How much flour does she need?
- _____

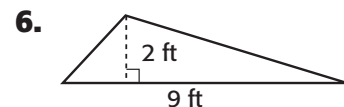
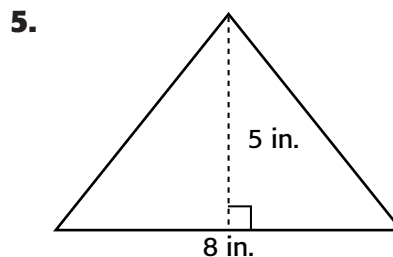
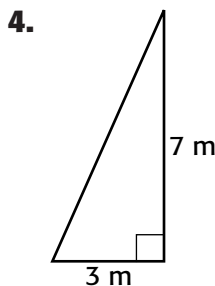
Spiral Review**Find the area of each triangle. (Lesson 11-4)**

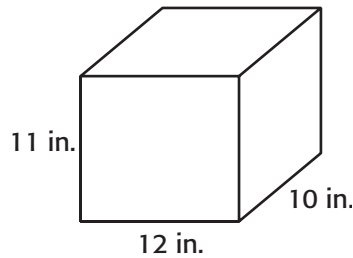
Homework Practice**5MG1.3, 5MG1.4***Volume of Rectangular Prisms***Find the volume of each prism.****1.**

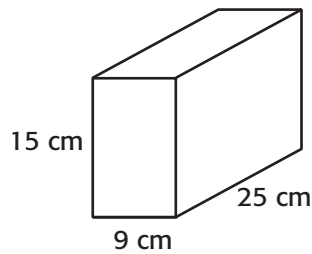
2.

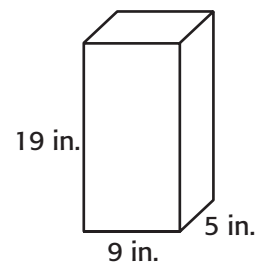
3.

- 4.** What is the volume of a rectangular box that has a base of 50 in^2 and a height of 12 inches?

- 5.** Bernice made a rectangular wooden tool box that has a base of 50 cm^2 and a height of 35 cm. What is the volume?

Spiral Review**Use any strategy to solve. (Lesson 11-5)**

- 6.** Ali has a loaf of bread that he needs to slice for his family's dinner. How many cuts does he need to make if he needs 6 equal-size slices of bread?

- 7.** Maggie's older sister is repaying her student loans. Her loans, including interest, total \$9,985. How much are her monthly payments if she plans to repay the loans in 8 years?

Problem-Solving Practice**5MG1.3, 5MG1.4***Volume of Rectangular Prisms***Solve.**

1. Find the volume of the chest.

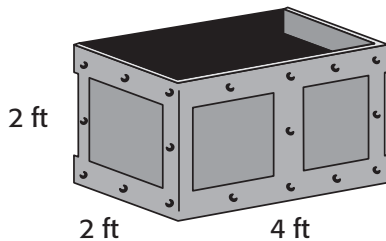

3. The Donaldson's swimming pool measures 15 m long, 8 m wide, and 3 m deep. How many cubic meters of water will the pool hold?

5. To save money, a local shipping company wants to purchase packing peanuts in bulk. The plant manager built a storage container that is 4 yd long, 10 yd wide, and 2 yd tall to store the peanuts. If the manager purchases bags that contain 7 ft^2 of peanuts, how many bags of peanuts will it take to fill the container?

2. How many cubic inches are in a cubic foot?

How many cubic feet are in a cubic yard?

4. Myra is baking a cake in a pan that measures 9 in. by 13 in. by 2 in. How many cubic inches of cake will the pan hold?

6. Paul is shopping for a refrigerator. He needs to compare the sizes and volumes to decide which refrigerator to buy. He needs a refrigerator with the dimensions shown below in order to fit in his kitchen. Find the volume of the refrigerator.

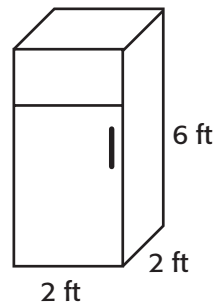

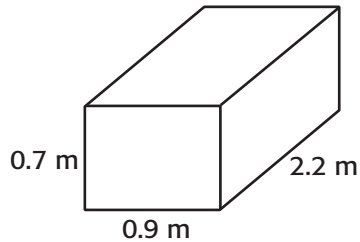
Homework Practice**5MG1.2***Surface Area of Rectangular Prisms***Find the surface area of each rectangular prism.****1.**

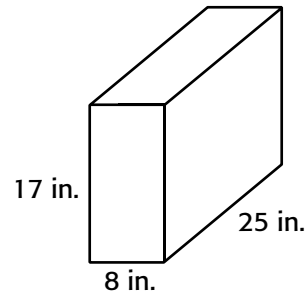
2.

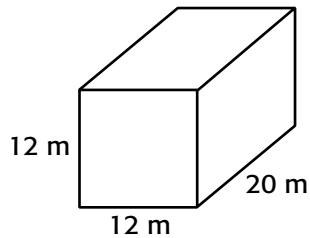
3.

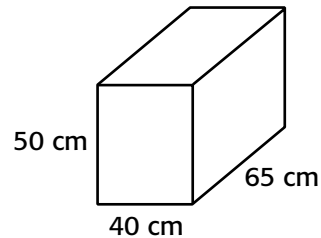
4.

- 5.** Alejandra wants to find the surface area of her aquarium. It does not have a top, and it measures 30 inches long by 20 inches high by 14 inches wide. What is the surface area?

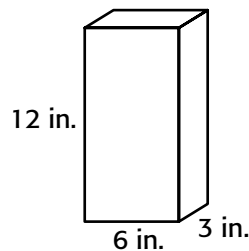
Spiral Review**Find the volume of each prism. (Lesson 11-6)****6.**

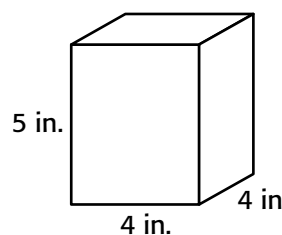
7.

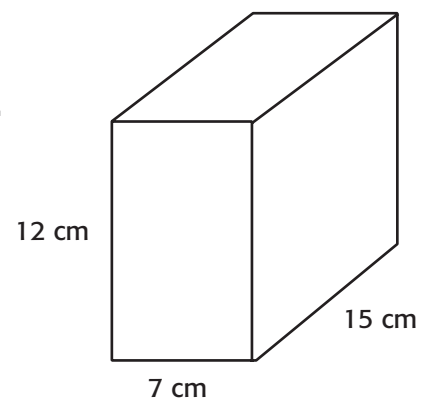
8.

Problem-Solving Practice**5MG1.2***Surface Area of Rectangular Prisms***Solve.**

1. Dylan has a toy box he wants to paint. He needs to find the surface area of the box in order to determine how much paint to buy. What is the surface area of the toy box?

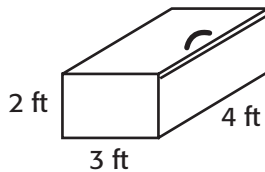

2. Julia has a music box that she wants to cover with fabric. How many square inches of fabric will she need to cover the music box?

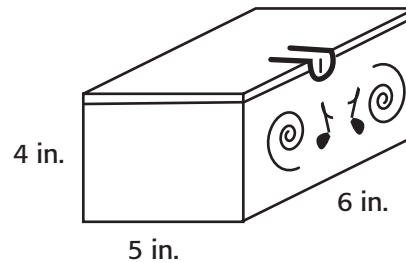

3. Jose is moving to a new house and has several packing boxes that are 2 ft by 2 ft by 3 ft. What is the surface area of each box?

4. Lenny builds kitchen cabinets that measure 3 ft tall, 1.5 ft long, and 2 ft deep. What is the surface area of each cabinet?

5. Lenny installs one of his kitchen cabinets in a corner, attached to the ceiling. What is the surface area of the exposed faces?

6. Lenny installs two of his cabinets, side-by-side on a wall, attached to the ceiling. What is the surface area of the exposed faces?
